

Interrogation of the IEC61850 message status in SIPROTEC 4 devices

One of the advantages in the new communication standard IEC61850 is the facility to interrogate the status of each transferred message. Where the interruption of a connection cannot be detected with conventional wiring, the signal transmission with IEC61850 has an integrated continuous monitoring which indicates failure of the connection or the transmitter.

Why is it not possible to detect a failure with convention wiring via binary input?

When applying a single point annunciation to a binary input of a SIPROTEC device, the status is either 1 (High) or 0 (Low), given that the configuration is „active with voltage“: In this case the annunciation is detected as COMING or ON when the binary input has status 1 (High), e.g. when a voltage of 110V DC is applied. Correspondingly the annunciation is GOING or OFF when there is no voltage applied to the binary input. However, an interruption of the circuit or loss of the connection will also activate the state 0 (Low) in the protection device. As a result, the true state is not known to the protection device.

(Due to this limitation, double point indications are implemented. These simultaneously interrogate two binary inputs and expect unambiguous High-Low combinations. Disadvantage: more binary inputs are required).

A loss of signal can also occur on protocol based communication links

A signal interruption can of course also occur during signal transmission. Communication failure messages are already available for other communication protocols (for example Profibus DP). These are generated when the own communication module on the processor module is not functioning. If an external failure arises, the communication module will not detect this. Possible sources of failure external to the SIPROTEC device may be loose connection cables or defective switches as well as the failure of a transmission device (refer to system overview diagram Figure 1).

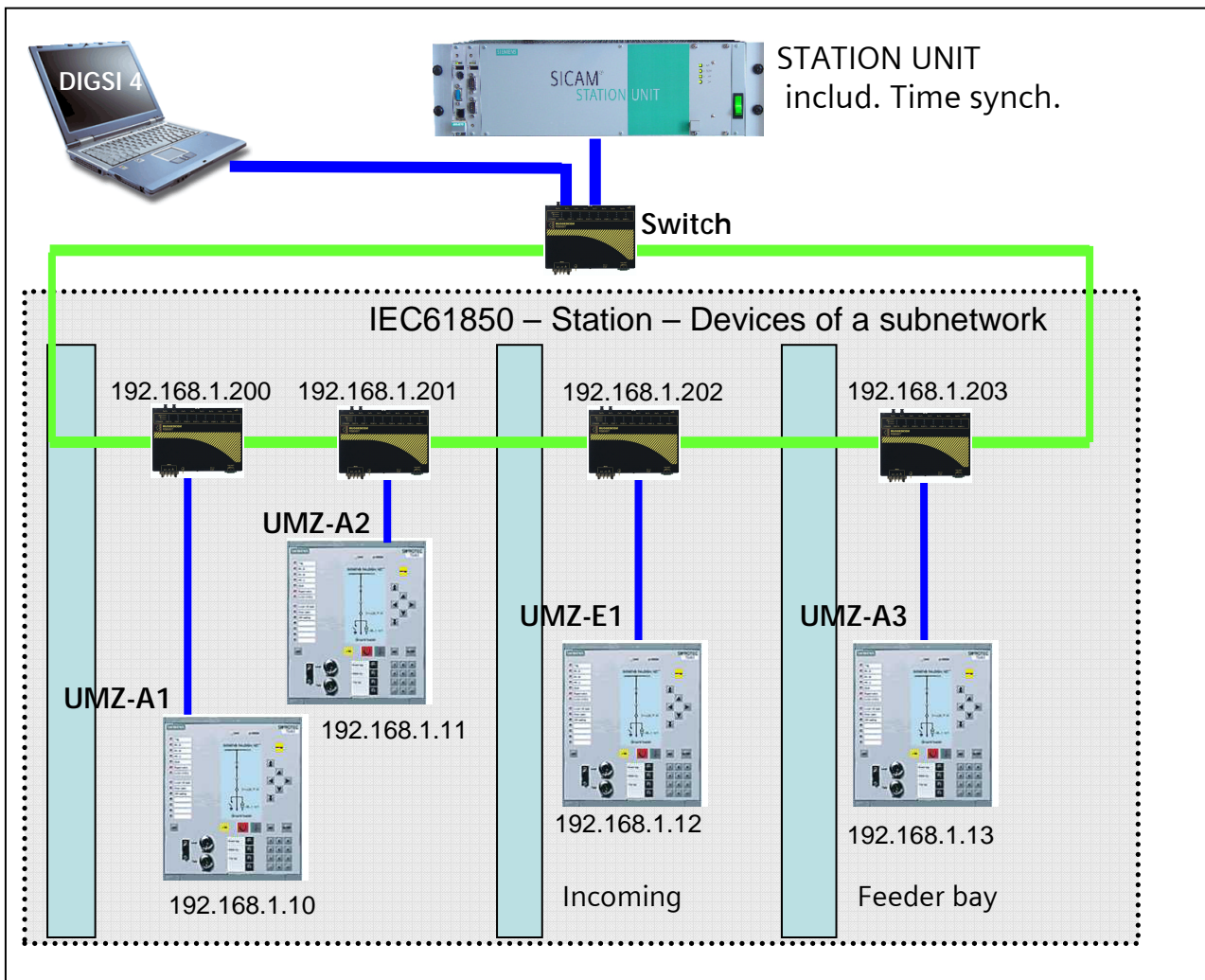

Figure 1: Example of an IEC61850 configuration: The sending device transmits a message to the receiving device via switches

Why does IEC61850 detect an interruption of the transmission path?

Transmission of the message from the sending end to the receiver is cyclic, even if no change of signal state occurs. The quiescent state (ON or OFF) is transferred to the receiver on a cyclic basis. Thereby, monitoring of the signal can be done by the receiver as the signal must be received at pre-determined intervals. If reception of the signal does not take place, then it is possible for the receiving end to determine that there is no longer a connection to the sending end. This interruption is indicated by a non-valid status at the receiving end.

A further advantage is: A group alarm only indicating a general failure does not arise, but rather each message includes its own status for interrogation. In the event of a signal path interruption, only those messages that are no longer transferred obtain the status "not valid".

How does one obtain the message status?

For this explanation, the application with bay overlapping interlocking is used (Figure 2): A protection device in the feeder bay of a double busbar substation is used for control. The switchgear is interlocked to prevent incorrect switching operation. For changing the busbar connection, the isolators Q1 and Q2 in the feeder bay may only be operated when a release from the bus coupler bay is present. The release message from the bus coupler is issued when the circuit breaker Q0 and isolators Q1 and Q2 (all belonging to the bus coupler) are closed, thereby providing a correct coupling of the two busbars via the bus coupler. In this manner it is ensured that an incorrect change over of busbars is not done via the isolators of the feeder bay.

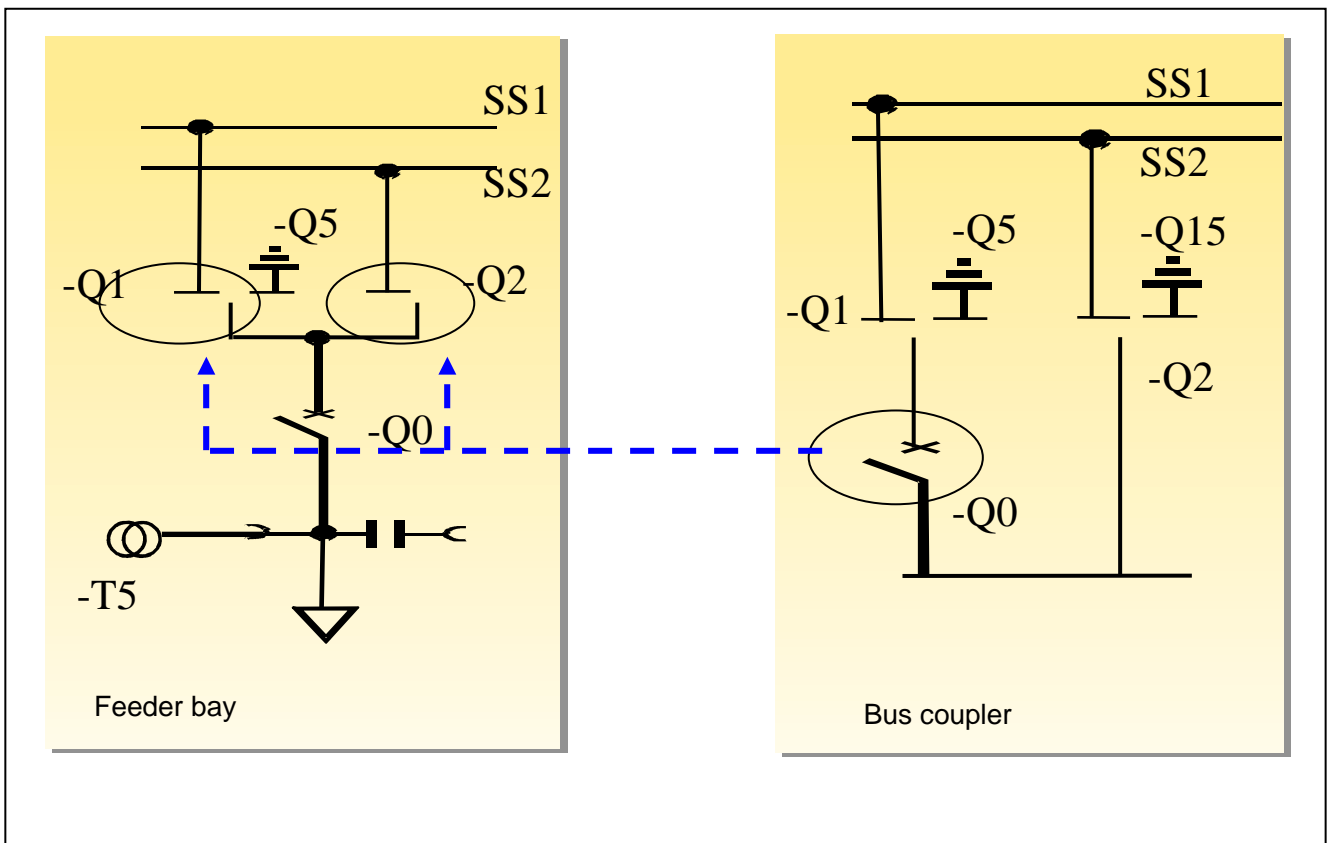

Figure 2: Bay overlapping interlocking: bus coupler provides release signal to the feeder bay

With IEC61850 communication the signal transfer can be shown in a simplified manner (Figure 3). The protection device in the bus-coupler corresponds to the transmitting device providing the release signal to the receiving device in the feeder bay.

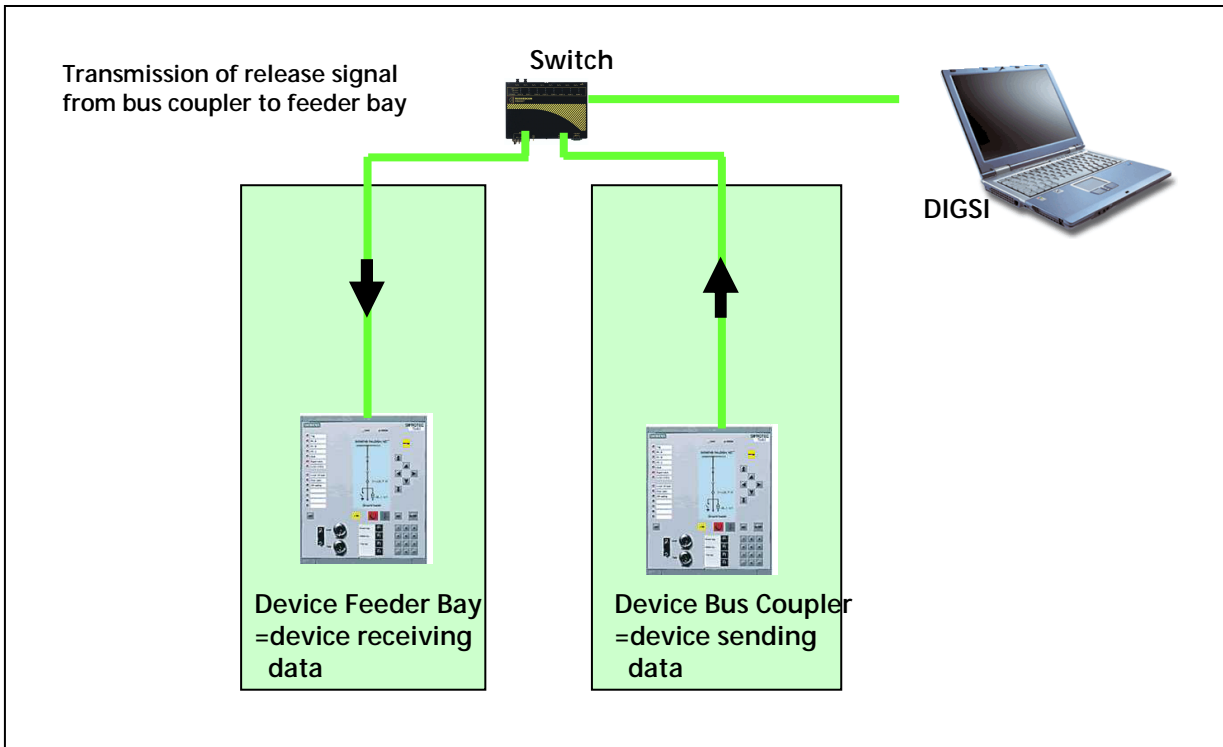

Figure 3: Simplified representation of the release signal transfer from the bus-coupler to the feeder bay

In the device located in the bus coupler the release signal is assigned with destination system interface (destination S) within the input/output matrix. The receiving device in the feeder bay requires a message type „External Single Point ExSP“ (refer Figure 4). This message is assigned to source S to obtain the release signal via the communication interface.

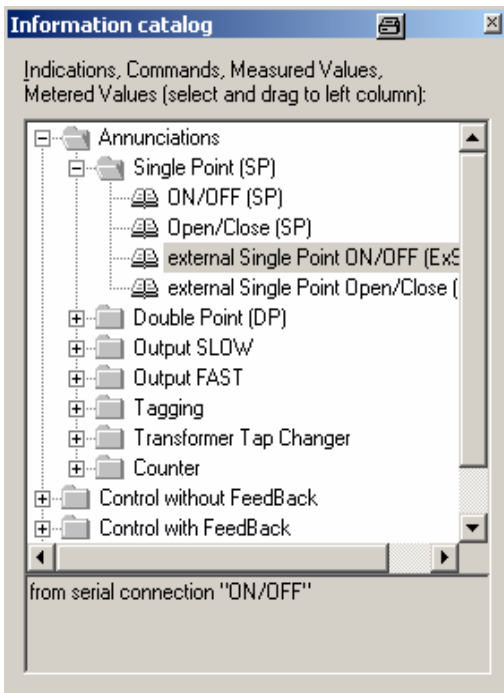

Figure 4: External single point indication (ExSP) for the matrix to receive the message from source S

In Figure 5 the annunciation for the receiving device is shown in the matrix. From source S the release for bus transfer is obtained (Type ExSP). This annunciation is allocated with destination CFC, where its status will be checked. The result will be a user-defined signal „Status valid/ not valid“. “Status valid/ not valid“ will appear as soon as the signal is no longer valid or when a communication disruption is present.

Device	Number	Display text	Information Long text	Type	Source				Destination									
					B	F	S	C	B	LE	BO	C	S	X	D	CM		
EN100-Modul 1	009.0100.01	Failure Modul	Failure EN100 Modul	IntSP														
	009.0101.01	Fail Ch1	Failure EN100 Link Channel 1 (Ch1)	IntSP														
	009.0102.01	Fail Ch2	Failure EN100 Link Channel 2 (Ch2)	IntSP														
Interlocking		Rel. bus	Release bus transfer	ExSP			X							X				
		Status	Status valid/not valid	SP				X										

Figure 5: Matrix of the receiving device in the feeder bay

Interrogation of the message status in CFC

The status of the IEC61850 annunciation obtained from the system interface is checked in CFC. For this purpose the logic module SI_GET_STATUS is provided.

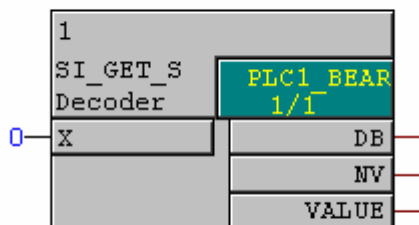

Figure 6: SI_GET_STATUS

The module SI_GET_STATUS decodes the status of a single point indication, whereby the structure of the single point indication routed to input X is decoded to the VALUE of the signal and the following status information:

I/O assignment:

	Name	Data type	Comment	Default selection
Inputs:	X	SIST	Single point indication with status	(0)
Outputs:	DB	BOOL	Chatter Blocking Chatter block is active (binary input is blocked).	0
	NV	BOOL	Not updated The value is not current. E.g. after start-up, communication failure, not configured (or configured to a non-existing or defective module).	0
	VALUE	WORD	Single point indication	16#0000

The output NV generates a signal NV=1, when the annunciation is no longer updated (update at second intervals). The signal from the NV output can then be routed to an LED or output contact. In the example at hand, the signal "Status valid/ not valid" (refer to Figure 5 matrix) is generated in this way. The module SI_GET_STATUS can be applied in all process layers; however Boolean inputs are not a trigger event in the MW_BEARB (measured value processing layer) and SFS_BEARB (interlock processing layer) and may therefore remain undetected if the event or signal is shorter than the execution interval of the particular processing layer.

At this point it is worth mentioning that the status of double point indications can also be interrogated in CFC. For this purpose CFC provides the module DI_GET_STATUS.

Result:

As long as the communication is functioning between the bus-coupler device and the device in the feeder bay, the present state of the bus release annunciation can be obtained without ambiguity. A communication failure results in the appearance of the status NV message via CFC.