

# Breaker Fail Protection for Transformer Bay with double (multiple) Busbar Configuration

## 1. Introduction

In this application example, the 7VH600 relay will be applied for breaker fail protection of the HV side breaker of a transformer bay. External trip signals and breaker status signals will be applied. The breaker fail protection will be two-stage with re-trip of the protected breaker followed by a trip to the surrounding breakers.

## 2. Single line diagram of the application

The configuration and connection of the protection is shown in Figure 1 below:

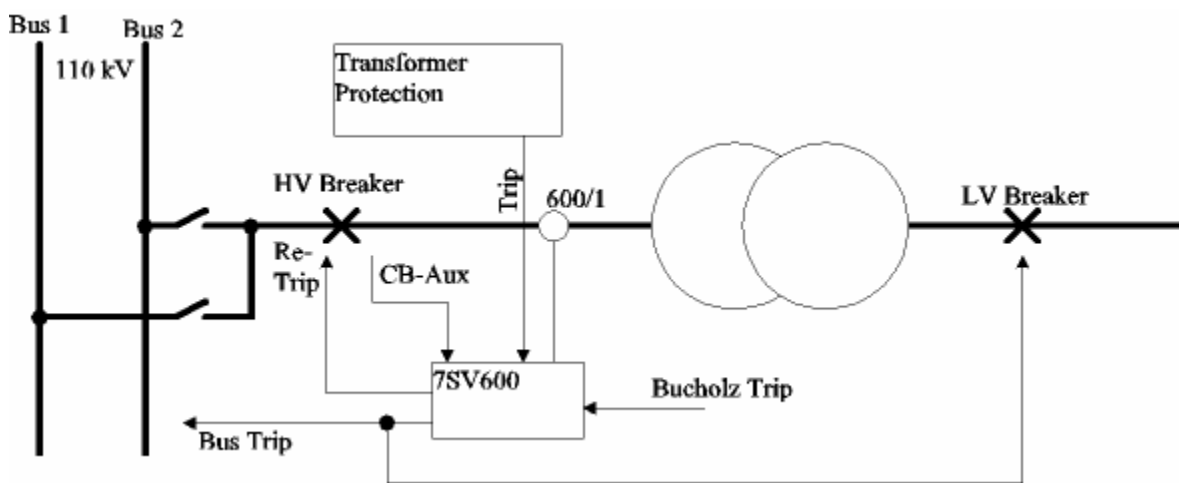

Figure 1: Single line diagram of application

The breaker fail relay must provide the redundant trip (re-trip) of the HV circuit breaker without time delay, and in the event of a breaker fail condition follow up with a “Bus Trip” command that trips the adjacent breakers. The routing of the “Bus Trip” in accordance with the isolator switching state will be done by the Busbar Protection which includes the required isolator replica. [Siemens busbar protection systems, e.g.7SS52, have binary input signals that provide for the coupling of the “Bus Trip” from external breaker fail relays.

## 3. Breaker Fail Protection

The 7SV600 in this application will provide breaker fail protection for the HV Breaker of the power transformer shown in Figure 1. Breaker fail protection monitors the current flow via the connected CT to confirm that the current goes to zero when the circuit breaker opens following a trip command from the transformer protection. If the breaker failure protection detects that there is still current flow a set time after the trip signal was issued, it will initiate tripping to all the surrounding breakers connected to the monitored breaker. In this example, the isolator replica provided by the busbar protection is utilized to route the “Bus Trip” signal to the relevant breakers on Bus 1 and Bus 2 depending on the switching status of the busbar isolators.

The main protection functions route their trip signals directly to the relevant circuit breakers as well as signaling the trip command to the breaker fail relay. In this example the breaker fail relay is used for an immediate re-trip command to the monitored breaker (trip coil 2). This provides a redundant path for the trip command to the circuit breaker and also ensures that the breaker fail protection always first trips the monitored breaker before, after the monitoring time delay, the “Bus Trip” signal can be issued. If for example due to a testing or other failure the breaker fail relay is accidentally initiated (simulated protection trip) the breaker fail relay will only trip the protected feeder and then reset when the current via the CT goes to zero. An incorrect bus trip due to such a contingency in the substation is therefore avoided.

Bucholz protection trip input is connected separately because this protection function is not associated with a short circuit current measurement. Here the circuit breaker auxiliary contacts will be monitored to obtain confirmation that the circuit breaker opened correctly.

#### **4. Allocation of the binary input signals**

The 7SV600 only has three physical binary inputs. The most important external signal for the breaker fail relay is the trip signal from the main protection (in this example the Transformer Protection). This is allocated to binary input function 7703 “>Strt3p” - Start breaker failure protection three-pole (common phase initiation).

Certain protection trip signals are not dependant on fault current, e.g. Bucholz Protection. The breaker fail function can therefore not use current flow as criterion for detecting the switching state of the circuit breaker. Even the drop of current magnitude from e.g. full load to almost zero, is not a clear indication that the HV Breaker is open because following a Bucholz trip and opening of the LV breaker only magnetizing current (typically less than 1% of full load current) flows. For secure operation of the breaker fail function in this case, a special input is used for the Bucholz trip. The binary input function 7704 “>St.wol” – Start breaker fail protection three-pole without current, is allocated for this purpose.

For the initiation without current mentioned above, the switching status of the circuit breaker is monitored from the state of the auxiliary contacts. The binary input function 355 “>CB 1pC” – Circuit breaker closed (from CB auxiliary contact) is allocated for this purpose.

For the binary inputs, the configuration shown below in Figure B.5 (extract from relay manual) is used.

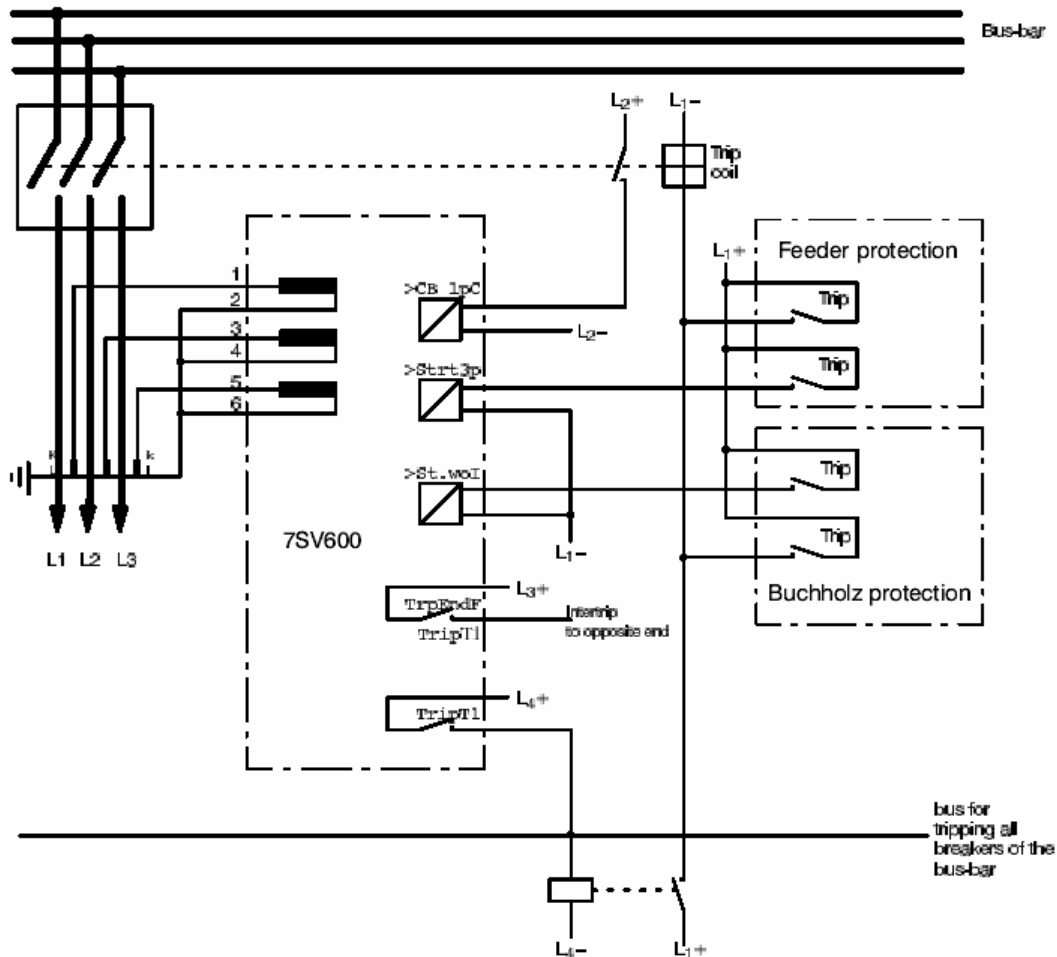

Figure B.5 Connection example for single-stage breaker failure protection with common phase initiation and Buchholz protection, CB interrogation is imperative; additional intertrip signal to the opposite line end in case of breaker failure or end fault

## 5. Allocation of the trip relay outputs

The trip output in this example will be different to that shown in Figure B.5 above. In this example two stages will be used, Trip T1 for trip repetition to the HV circuit breaker via the second trip coil and Trip T2 for “Bus Trip” to the busbar and the LV circuit breaker. Therefore, allocate K1 with 7710 “TripT1” – Breaker failure protection: trip with T1 (1<sup>st</sup> stage) and K2 with 7711 “TripT2” – Breaker failure protection: trip with T2 (2<sup>nd</sup> stage). The End-Fault protection must in the case of a fault between the circuit breaker and CT provide a trip command to the LV side circuit breaker. As the “end fault” is inside the HV busbar protection coverage, the End-Fault trip is also assigned to the tripping relay K2 so that it repeats the busbar trip and trips the LV side circuit breaker. For this purpose also allocate K2 with 7713 “Trip by End-Fault protection”.

## 6. Applying the relay Configuration and Marshalling

In the “Configuration” and “Marshalling” only the relevant parameters are defined here. A number of further settings used for signaling, communication, fault recording etc. are not defined in this application example as they do not affect the protection function.

## 6.1. Configuration

Depending on the version (MLFB) of the 7SV600, settings in the “Configuration” must be applied.

INTEGRATED OPERATION – 7800 SCOPE OF FUNCTIONS		
Address	Function	Value
7816	Breaker Failure Protection	Three-pole

For this application three pole tripping must be applied as shown above for Address 7816.

The other settings in the “Configuration” are not relevant to the protection functions covered in this application example and may be set according to the users specific requirements.

## 6.2. Marshalling Binary Inputs

The 3 binary inputs of the 7SV600 must be assigned as described above under Heading 4 “Allocation of the binary input signals”.

MARSHALLING – 6101 MARSHALLING OF BINARY INPUT 1		
Address	Function	Value
6102	BINARY INPUT 1 1 <sup>st</sup> FUNCTION	
001	7703 > BF external start 3-pole	Active with voltage

The first binary input will be used for the 3 pole trip signal from the transformer main protection, it is assigned as shown above to 7703 “>BF external start 3-pole”.

MARSHALLING – 6122 MARSHALLING OF BINARY INPUT 2		
Address	Function	Value
6123	BINARY INPUT 2 1 <sup>st</sup> FUNCTION	
001	7704 > BF external start 3-p. without current	Active with voltage

The second binary input will be used for the 3 pole trip signal from the Bucholz protection which must initiate breaker fail protection without current monitoring. It is assigned as shown above to 7704 “>BF external start 3-p. without current”.

MARSHALLING – 6133 MARSHALLING OF BINARY INPUT 3		
Address	Function	Value
6134	BINARY INPUT 3 1 <sup>st</sup> FUNCTION	
001	0355 > CB aux. contact: 1 pole closed (parallel)	Active with voltage

The third binary input is assigned to monitor the circuit breaker auxiliary contact status. It must be connected such that when 1 or more CB poles are closed the input is “high”. It is assigned as shown above to 0355 “>CB aux. contact: 1pole closed (parallel)”.

## 6.3. Marshalling Command Relays

The first of the 2 command relays in the 7SV600 is used for a re-trip to the monitored circuit breaker via the 2<sup>nd</sup> trip coil.

MARSHALLING – 6401 MARSHALLING OF COMMAND RELAY 1		
Address	Function	Value
6402	COMMAND RELAY 1 1 <sup>st</sup> CONDITION	
001	7710 Breaker failure Trip T1 (local Trip)	

For this purpose the condition 7710 “Breaker failure Trip T1 (local Trip)” is assigned to the command relay 1 as shown. All the command relays have two separate contacts that may be connected according to the scheme requirement.

The second of the 2 command relays in the 7SV600 is used for the “Bus Trip” signal that is routed to the circuit breakers connected to the busbar via the isolator replica of the busbar protection.

MARSHALLING – 6422 MARSHALLING OF COMMAND RELAY 2		
Address	Function	
6423	COMMAND RELAY 2 1 <sup>ST</sup> CONDITION	
001	7711 Breaker failure Trip T2 (Busbar Trip)	

For this purpose the condition 7711 “Breaker failure Trip T2 (Busbar Trip)” is assigned to Command Relay 2 as shown.

## 7. Applying the relay Settings

Under the heading “Settings” there are a number of subsections that have to be configured in accordance with the application:

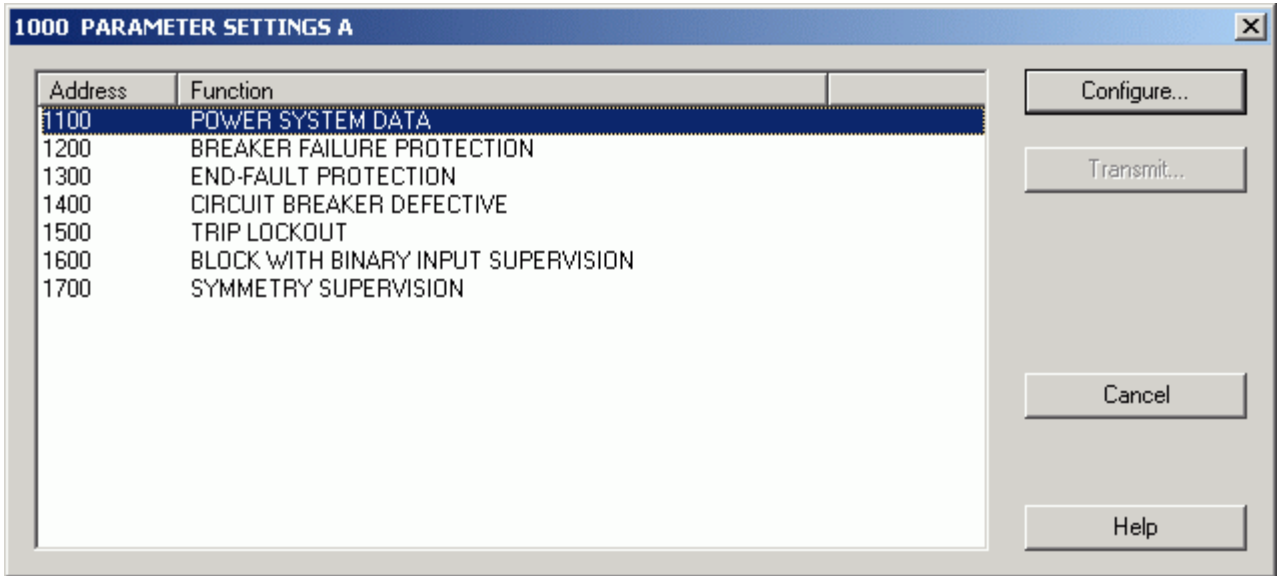

Figure2: Screen shot of subsections under the Heading "Settings"

### 7.1. Setting Power System Data

The following settings are applied in the subsection “Power System Data”, according to the information in Figure 1:

PARAMETER SETTINGS A – 1100 POWER SYSTEM DATA		
Address	Function	Value
1101	Rated system frequency	fN 50 Hz
1105	Primary rated current	600 A
1134	Minimum trip command duration	0.15 s

The system frequency must be set accordingly, either 50 or 60 Hz. The primary rated current refers to the CT primary. It is not relevant to any protection functions, but only used for the fault recording.

The minimum trip command duration must be set longer than the maximum time taken by the circuit breaker to trip following initiation of a trip command (time from start of trip command until circuit breaker auxiliary contacts indicate that the circuit breaker is open). In this case the circuit breaker requires 75 ms. By including a safety margin of 50 ms a setting of 150 ms is obtained.

## 7.2. Setting Breaker Failure Protection

For the breaker fail protection the following settings must be applied.

PARAMETER SETTINGS A – 1200 BREAKER FAILURE PROTECTION		
Address	Function	Value
1201	Breaker Failure Protection ON/OFF	on
1202	Current pick-up for Breaker Fail	0.16 I/In
1204	Local trip time delay (T1): 3pole	0.00 s
1205	Busbar trip delay (T2)	0.15 s
1206	Extended criterion for Drop Off	Yes

The breaker fail protection function is set to “on” with parameter address 1201. The current threshold for breaker failure protection must be carefully selected. For breaker fail there are two basic philosophies:

- a) Very secure breaker fail uses a current threshold that is greater than the maximum load. In this manner the “Bus Trip” command can only be issued if following a trip command and breaker failure the fault current flowing via the breaker is greater than full load current. This approach was often applied with analog protection relays.
- b) A very sensitive breaker fail uses a current threshold that is equal (marginally smaller) than the most sensitive protection operation that can issue a trip to the monitored circuit breaker. This approach is very secure as every protection operation will result in fault clearance by the breaker fail relay if the circuit breaker does not respond in time. With modern numerical relays this approach is preferred because of the higher security achieved with these devices.

In this application the approach b) is followed. The most sensitive protection stage, apart from the Bucholz protection, is the transformer differential protection. Here a setting of 15% of nominal current is applied for transformer differential protection so that the setting for the breaker fail, with 20% margin, can be calculated as follows:

$$I_{BF} = 0.8 \cdot I_{DIFF}$$

$$I_{BF} = 0.8 \cdot 0.2 \cdot I_N$$

$$I_{BF} = 0.16 \cdot I_N$$

The setting for 1202 “Current pick-up for Breaker Fail” is therefore applies as 0.16 I/In.

The time delay for the first stage, 1204 “Local trip time delay (T1): 3pole”, is set to zero because this stage is only used to re-trip the monitored breaker via the second set of trip coils.

The second time delay for stage 2, 1205" Busbar trip delay (T2)", must be calculated to ensure selectivity of the breaker fail protection:

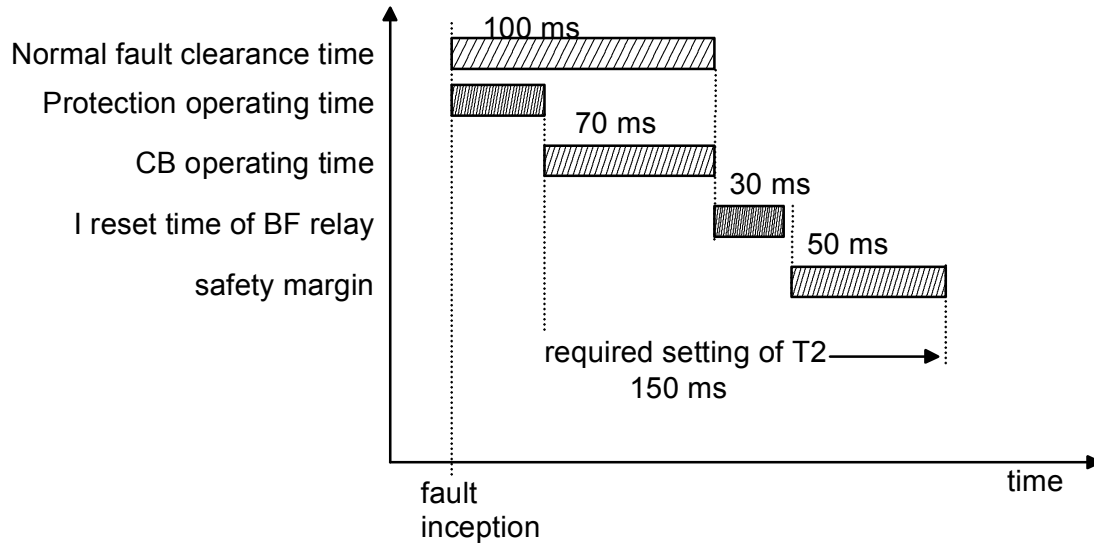

**Figure 3: Timing diagram to determine T2**

The time T2 in the breaker fail relay is started with the trip command of the protection. If the circuit breaker opens in the normal manner following the trip command, the current flow via the breaker is interrupted. In this example the circuit breaker opening time is given as 70 ms. If a further 30 ms are considered for resetting of the current measurement of the 7SV600 then a drop off occurs 100 ms after the trip. As shown in Figure 3 a safety margin of 50 ms is applied so that the set time for T2 is 150 ms.

The setting 1206 is used to enable the CB auxiliary contact monitoring for breaker fail protection initiation with "St.wol" (start without current). In this example, the Bucholz protection is initiating this input so that the setting of 1206 "Extended criterion for Drop Off" must be Yes.

### 7.3. Setting End Fault Protection

The End-Fault protection provides selective fault clearance of faults between the circuit breaker and the CT (refer to Figure 1). A fault at this position is not covered by the transformer protection, but is inside the busbar protection fault coverage. The trip of the busbar protection must therefore be connected in parallel with the transformer protection initiation of the breaker fail relay. The busbar protection trip will however not isolate the fault because there is still infeed from the LV side of the transformer. The End-Fault protection must provide the trip command to the LV side circuit breaker.

For the end fault protection the following settings must be applied.

PARAMETER SETTINGS A – 1300 END-FAULT PROTECTION		
Address	Function	Value
1301	End-Fault Protection	on
1302	Time delay for trip by End-Fault Protection	0.10 s

The End-Fault protection is applied so the parameter 1301 must be set to “on”. The time delay 1302 is started when during breaker fail initiate condition, the circuit breaker auxiliary contacts indicate that the CB is open but the current flow continues. When the time expires the End-Fault trip is issued. The time must allow for the current measurement reset time of the 7SV600 (30 ms) as well as timing difference between the CB primary and auxiliary contacts (20 ms) plus a safety margin of 50 ms. The applied setting is therefore 100 ms.

#### 7.4. Setting Breaker Defective, Trip circuit seal in, Blocking and Monitoring functions

The breaker defective function is not used, as it requires further binary input information regarding the health state of the circuit breaker which is not available in this application. Therefore set as shown in the table below.

PARAMETER SETTINGS A – 1400 CIRCUIT BREAKER DEFECTIVE		
Address	Function	Value
1401	Handling of Binary Input ‘CB defective’	no
1402	Time delay for trip by BI ‘CB defective’	0.00 s

The lockout function can be used to seal in the breaker fail trip output. Thereby reclosure can be prevented until the lockout is reset. In this application the lockout function is not used, therefore apply the settings as shown below.

PARAMETER SETTINGS A – 1500 TRIP LOCKOUT		
Address	Function	Value
1501	Operating mode of Lockout function	no
1502	Reset of Lockout	via LED-quit button

The blocking of the breaker fail protection by monitoring of the binary inputs can be applied if dual channel initiation is applied or with phase segregated initiation. In this application simple three pole initiation is applied so the monitoring of the binary input plausibility is not possible. Therefore apply the following settings.

PARAMETER SETTINGS A – 1600 BLOCK WITH BINARY INPUT SUPERVISION		
Address	Function	Value
1601	Block BF-protection via supervision	off
1602	Time delay for BF blocking by supervision	5.00 s
1603	Supervision of two-channel BF start	no

The current symmetry supervision can be used to alarm and/or trip the circuit breaker if a pole discrepancy condition is indicated by severe non-symmetry of the measured currents. In this example the symmetry monitoring will only be used to generate an alarm when the measured currents are not symmetrical. The following settings are applied.

PARAMETER SETTINGS A – 1700 SYMMETRY SUPERVISION		
Address	Function	Value
1702	Operating mode of current symmetry supervision	On
1703	Symmetry threshold for current monitoring	0.50 I/In

1704	Symmetry factor for current monitoring	0.50
1705	Time delay for current symmetry supervision	3 s
1706	Local Trip by current symmetry supervision	No

## **8. Conclusion**

Although the 7SV600 is a very compact device, it provides adequate breaker fail protection with special features such as current or auxiliary contact monitoring depending on the initiation (Diff trip or Bucholz trip). End-Fault protection and re-tripping is also included in this application example.