

Coordination of Inverse-Time Overcurrent Relays with Fuses

1. Introduction

The duty of protection equipment is to allow overload currents that occur during operation, yet to prevent impermissible loading of lines and equipment. To avoid damages in the case of short-circuits the relevant equipment must be tripped in the shortest possible time. On the other hand only as few feeders or loads as possible should be disconnected from supply.

The protection relays available in the power system must recognize the fault, perform tripping themselves or give trip commands for the relevant switching device.

The protection relays must be set to ensure selective tripping. Absolute selectivity is not always assured. "Selectivity" means that the series-connected protection relay nearest the fault first trips the faulted line. Other protection relays (further upstream) recognize the fault but trip only after a delay (backup protection).

In the following the use of HV HRC fuses (high-voltage-high-rupturing capacity) and inverse-time overcurrent-time protection relays (as well as their interaction) will be described. See Fig. 1.

2. Protective equipment

2.1 HV HRC fuses

The high-voltage-high-rupturing capacity fuse is a protective device suited for non-recurring shutdown in medium-voltage switchgear, in which the current is interrupted by the melting of a fusible element embedded in sand.

HV HRC fuses are used for short-circuit protection in medium-voltage switchgear up to 20 kV. Used upstream of transformers, capacitors and cable feeders, they protect equipment and system components from the dynamic and thermal effects of high short-circuit currents by shutting them down as they arise.

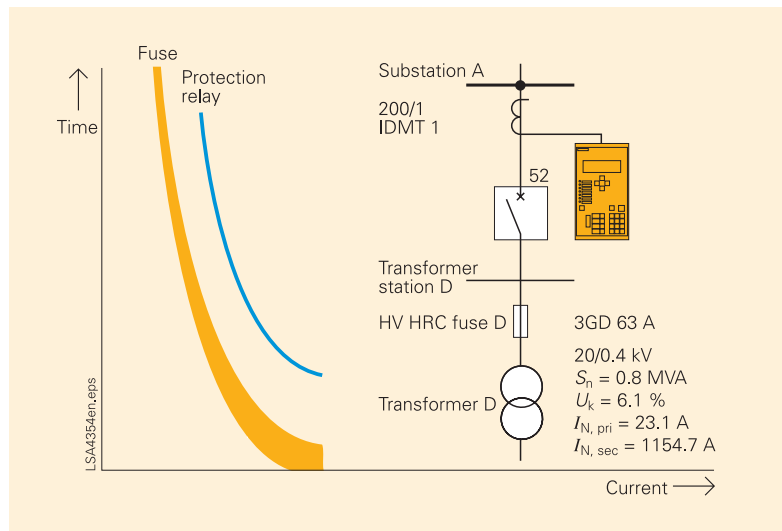

Fig. 1 Block diagram

However, they are not used as overload protection because they can only trip reliably as from their minimum breaking current. For most HV HRC fuse links the lowest breaking current is $I_{\min} = 2.5$ to $3 \times I_N$.

With currents between I_N and I_{\min} HV HRC fuses cannot operate.

When choosing HV HRC fuse-links, stressing of the fuse from earth-fault current or residual current must be considered.

HV HRC fuse-links are installed with high-voltage fuse-bases in the switchgear. They can also be installed in the built-on units of the switch disconnectors provided. By combining switch disconnector and HV HRC fuse, the I_N to I_{\min} current which is critical to the fuse can also be reliably broken. The switch is tripped by the fuse's striker and disconnects the overload current in the three phases. Some typical breaking characteristics are shown in Fig. 2.

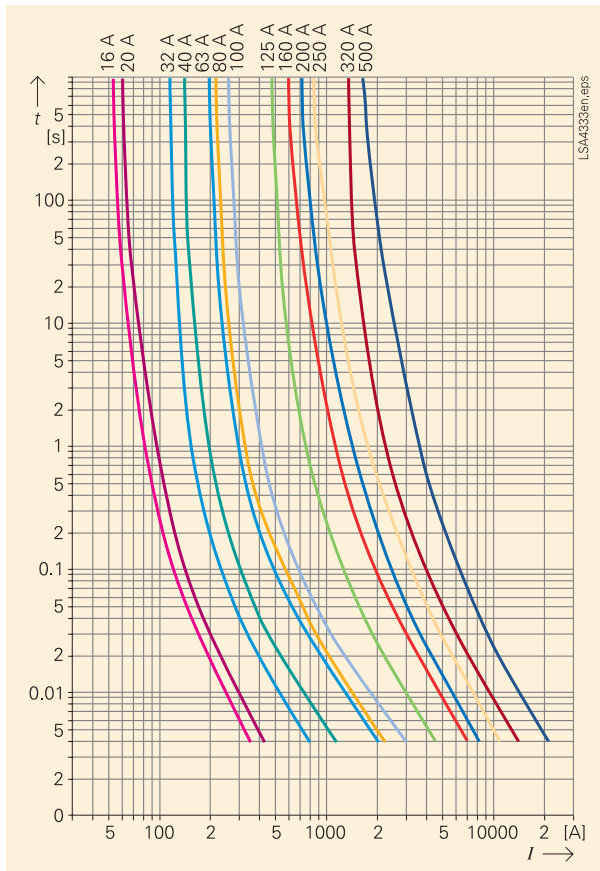

Fig. 2
Breaking characteristics of HV HRC fuses

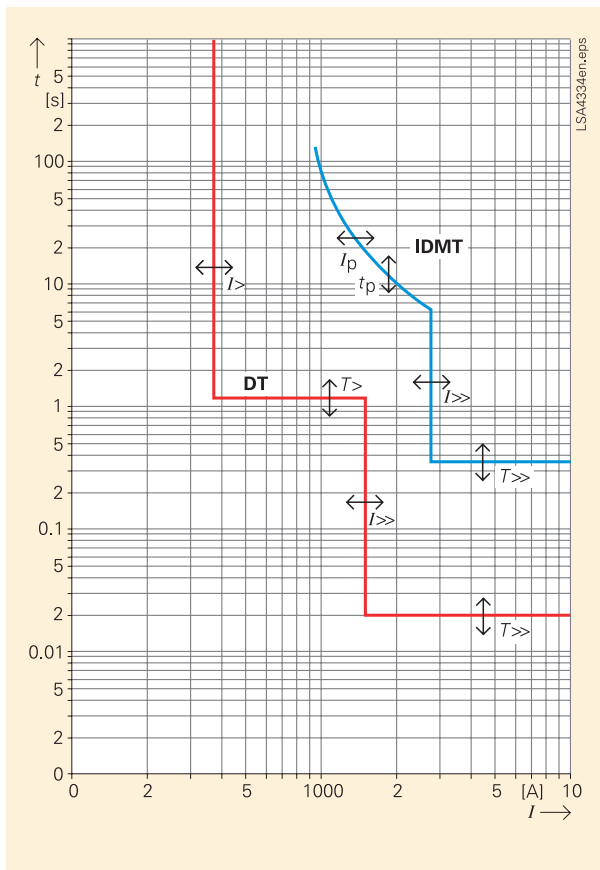

Fig. 3
Definite and inverse-time characteristics

2.2 Inverse-time overcurrent protection

Overcurrent protection is the main function of the 7SJ6 product range. It can be activated separately for phase and earth-fault currents.

The $I \gg$ high-set overcurrent stage and the $I >$ overcurrent stage always work with definite tripping time.

In the I_p inverse-time overcurrent stage, the tripping time depends on the magnitude of the short-circuit current.

Fig. 3 shows the basic characteristics of definite and inverse-time overcurrent protection.

For inverse-time overcurrent functions (I_p stages) various tripping characteristics can be set.

- Normal inverse (NI)
- Very inverse (VI)
- Extremely inverse (EI)
- Long time inverse (LI)

All characteristics are described by the formulae below. At the same time, there are also distinctions as follows:

	IEC/BS	ANSI
NI	$t = \frac{0.14}{(I/I_p)^{0.02} - 1} \cdot T_p$	$t = \left(\frac{8.9341}{(I/I_p)^{2.0938} - 1} + 0.17966 \right) \cdot D$
VI	$t = \frac{13.5}{(I/I_p) - 1} \cdot T_p$	$t = \left(\frac{3.922}{(I/I_p)^2 - 1} + 0.0982 \right) \cdot D$
EI	$t = \frac{80}{(I/I_p)^2 - 1} \cdot T_p$	$t = \left(\frac{5.64}{(I/I_p)^2 - 1} + 0.02434 \right) \cdot D$
LI	$t = \frac{120}{(I/I_p) - 1} \cdot T_p$	$t = \left(\frac{5.6143}{(I/I_p) - 1} + 2.18592 \right) \cdot D$
	t = Tripping time T_p = Setting value of the time multiplier I = Fault current I_p = Setting value of the current	

Table 1 IEC/BS and ANSI

The general IEC/BS characteristic is shown in Fig. 4 and that of ANSI in Fig. 5

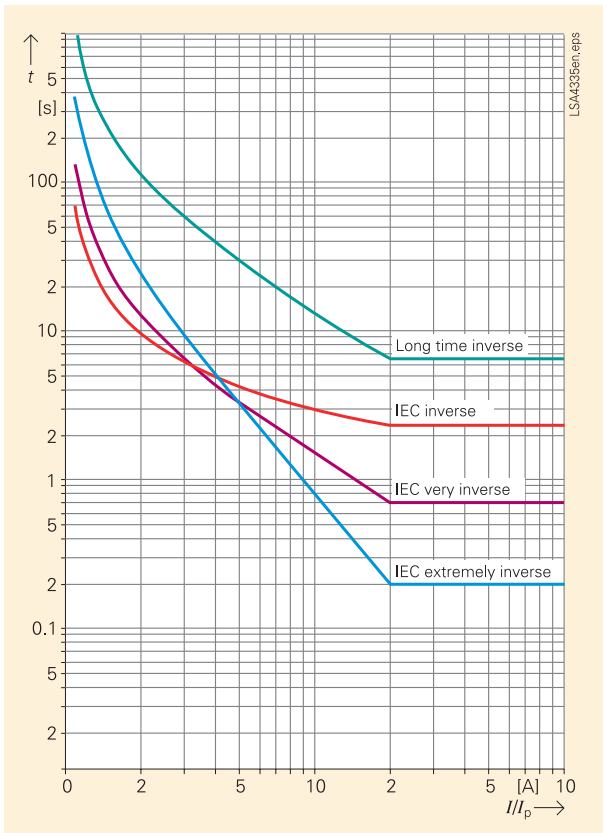

Fig. 4 IEC/BS characteristics

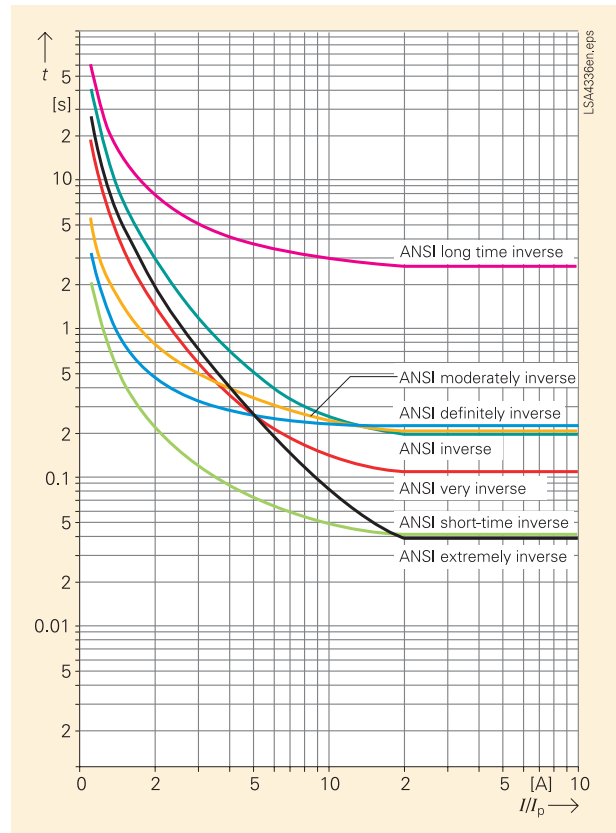

Fig. 5 ANSI characteristics

■ 3. Network circuit and protection concept

The topology of a distribution system should be as simple and clear as possible and ensure a reliable supply.

Individual transformer stations are supplied by ring cables. An example of a ring cable system is shown in Fig. 6.

In order that a fault does not cause the whole ring with all stations to fail, an “open” operating method is the standard. In this example, transformers are protected on the low voltage (LV) side with HV HRC fuses and the ring cable itself with an overcurrent-time relay.

3.1 Calculating the relevant system currents

The full load current and short-circuit strength are the selection criteria for the cable to be used. The transformer rated currents must not deviate too much from the rated currents of the cables used. The maximum and minimum short-circuit currents (3, 2, 1 phase) appearing in this power system section must be calculated before the parameters of the relays can be set. LV-side short-circuit currents must also be taken into account here. It is advisable to use programs such as SIGRADE (Siemens Grading Program) to calculate the short-circuit currents.

For further information please visit us at:
www.siemens.com/systemplanning

■ 4. Selection and setting of protective components

The HV HRC fuses are selected using tables that take into account transformer power (S_n), short-circuit voltage (U_{sc}) and rated voltage on the HV side. Using the short-circuit currents detected, a proposal can be worked out for selective protection setting of the inverse-time overcurrent functions:

- I_p must be set above the permissible rated current of the cable (around $1.5 \times I_N$ cable)
- $I >>$ should not trip in the case of a fault on the low-voltage side
- In the case of a max. short-circuit current in the MV system, there must be an interval of at least 100 ms between the tripping characteristic of the HV HRC fuse and the inverse-time characteristic. The time multiplier T_p must be set to get this safe grading time.

It must be borne in mind that the value of the time multiplier T_p (in 7SJ6 from 0.05 to 3.2 seconds) does not correspond to the genuine tripping time of the characteristic. Rather, the inverse-time characteristic can be shifted in parallel in the time axis by this value.

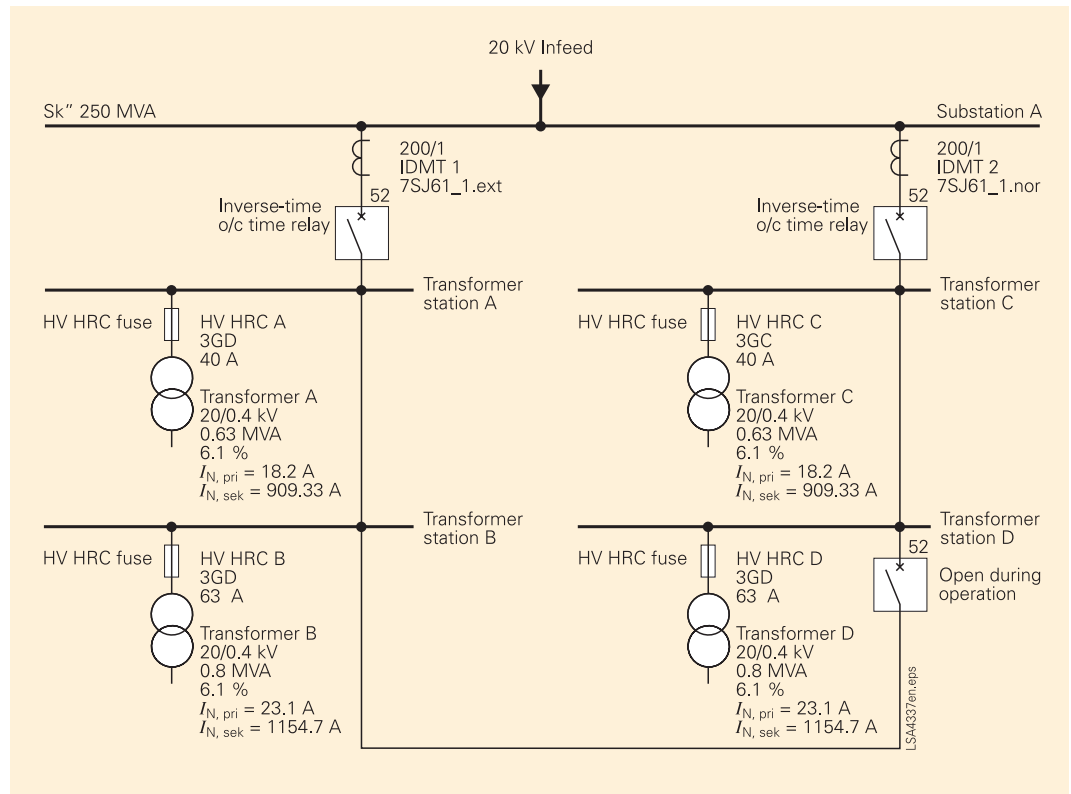

Fig. 6 Example of a 20 kV ring distribution system

■ 5. Proof of selective tripping

As mentioned earlier, selectivity means only the protection relay closest to the faulty system section trips. Protection equipment connected (upstream) in series must register the fault but only trip after a delay period. Typically, proof of selective tripping is shown in a current-time diagram with double logarithm scale. Programs like SIGRADE are also used for this.

For the power system sections in question, typical or critical time grading diagrams are selected.

Each protection relay has its own name, which describes the installation location. The same power system and protective elements shown in more than one time grading diagram have the same name.

The color of the name in the time grading path (left side of the diagram) matches the color of the set characteristic (in the time grading diagram on the right) in the current-time diagram. On the left side, in addition to the single-line circuit diagram (time-grading path) for each protection relay, the type name, the setting range and the set values are given.

In addition to the characteristics of the protection relay, the current-time diagram shows the short-circuit current ranges plotted with minimum and maximum values as bandwidth (values from the short-circuit calculation). These short-circuit

current bands always end on the voltage current scale. The right-hand characteristic in a band is the maximum short-circuit current (3 phase), calculated (here in green) from the incoming elements (generators, transformers, etc). The left-hand characteristic shows the minimum short-circuit current (1 or 2 phase) which is calculated on the basis of the impedances of the elements in the power system up to the location of the fault.

Band 1 (Transf. D Pr) shows the bandwidth of the 20 kV power system;
band 2 (Transf. D Sec) shows that of the 0.4 kV power system.

The above-mentioned bands are contained in the time-grading diagrams (Figs. 7 to 11).

■ 6. Grading of overcurrent-time relay and HV HRC fuse

As an example of the power system shown in Fig. 6, in 3 time sequence diagrams the most usual characteristics (NI, VI, EI) of the inverse-time overcurrent protection are shown with the corresponding HV HRC fuses characteristic. The overcurrent-time relay 1, HV HRC fuse D and transformer D are selected from the circuit diagram.

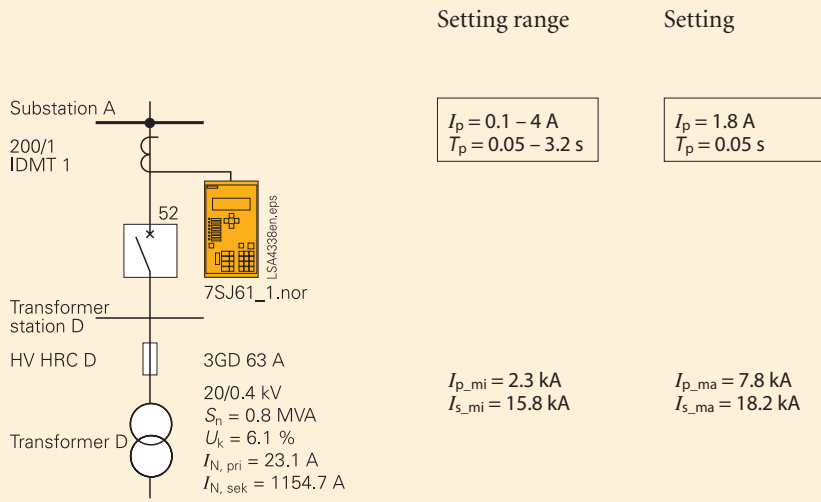

Overcurrent-time relay with "Normal Inverse" (NI) setting

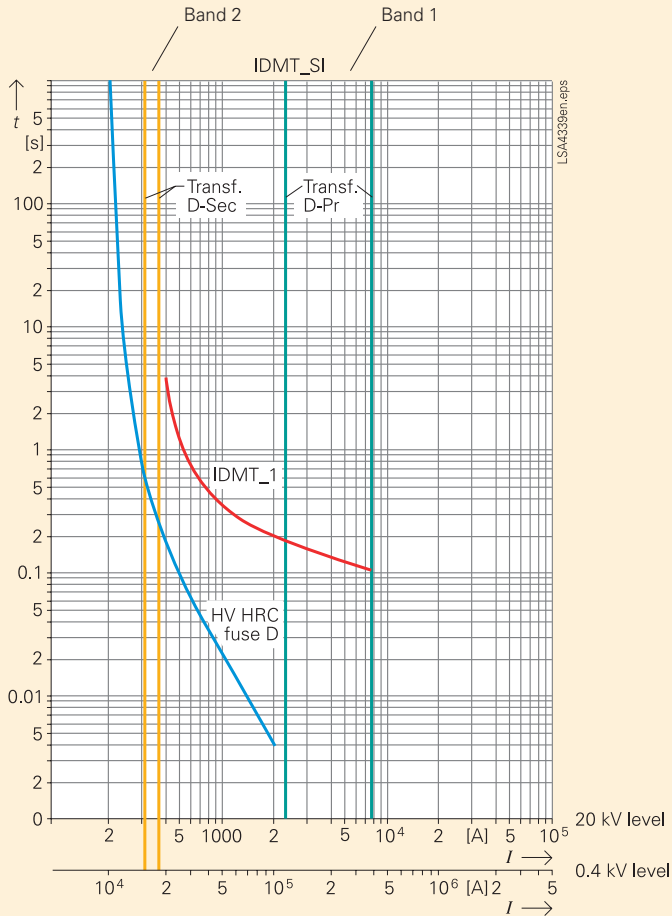

Fig. 7 Time-grading diagram, inverse-time NI

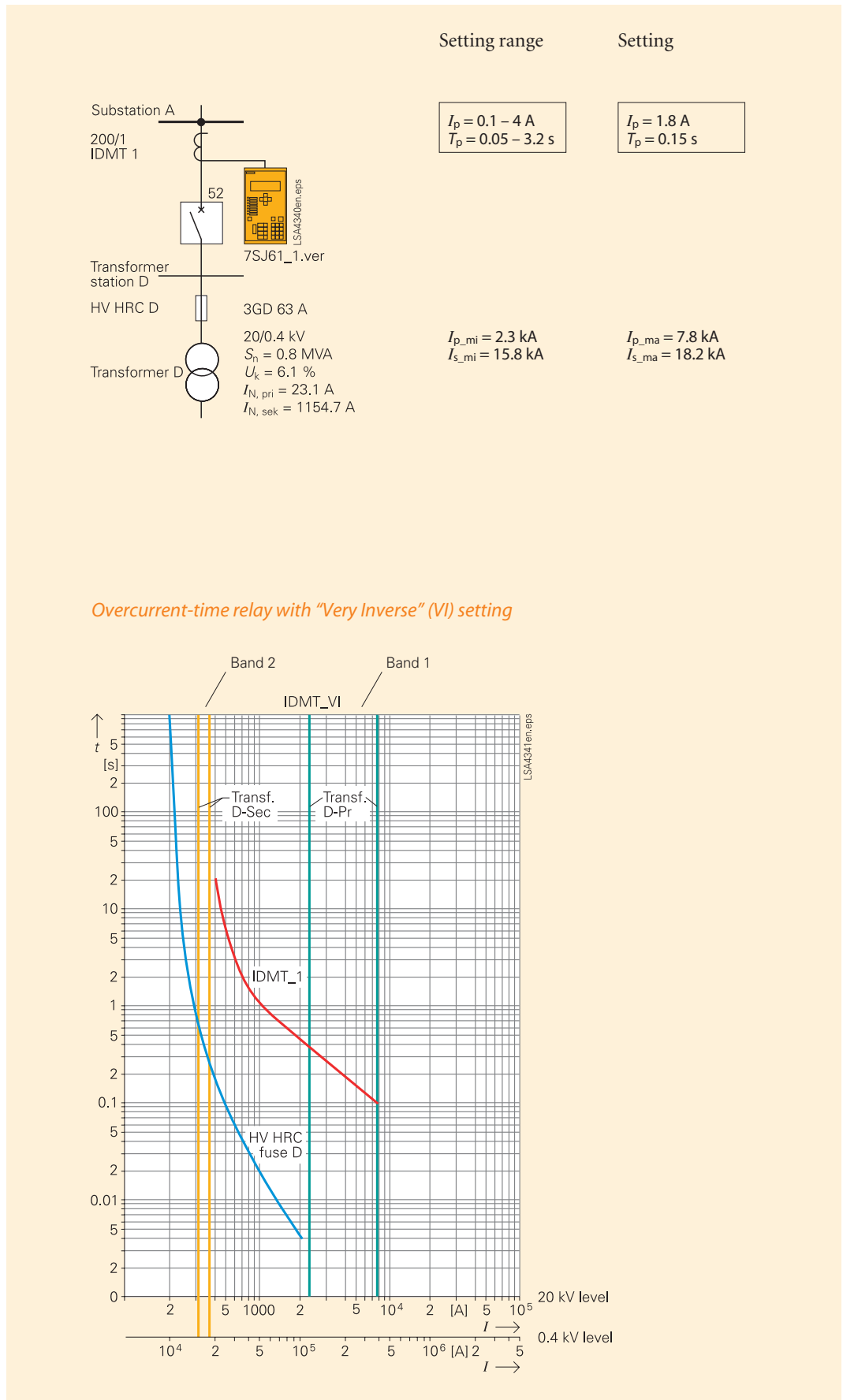
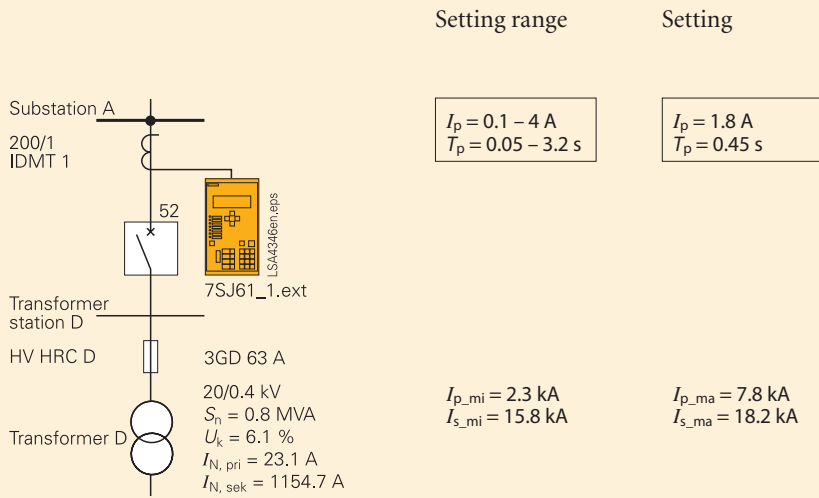

Fig. 8 Time-grading diagram, inverse-time VI



Overcurrent-time relay with "Extremely Inverse" (EI) setting

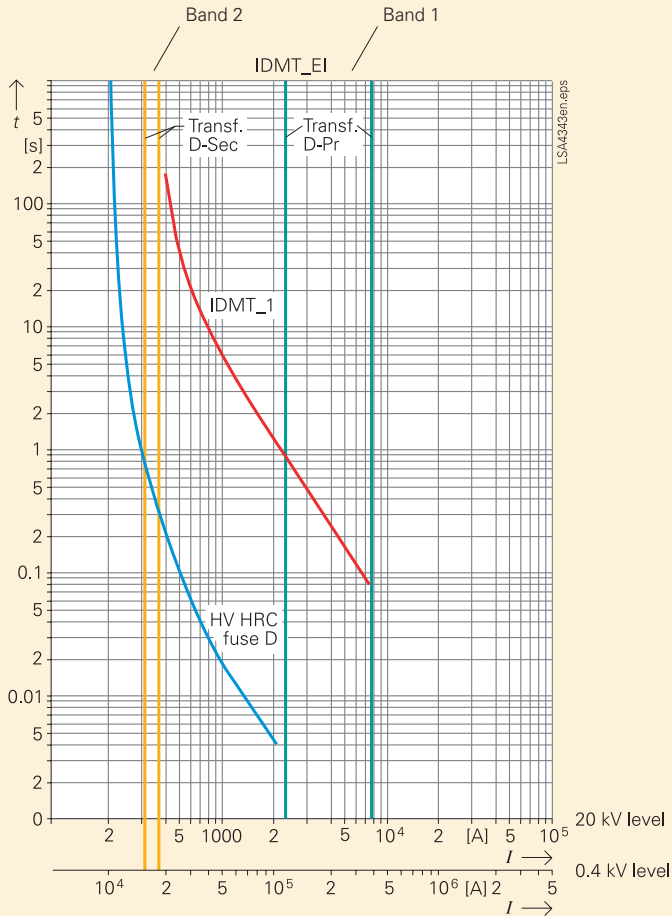

Fig. 9 Time-grading diagram, inverse-time EI

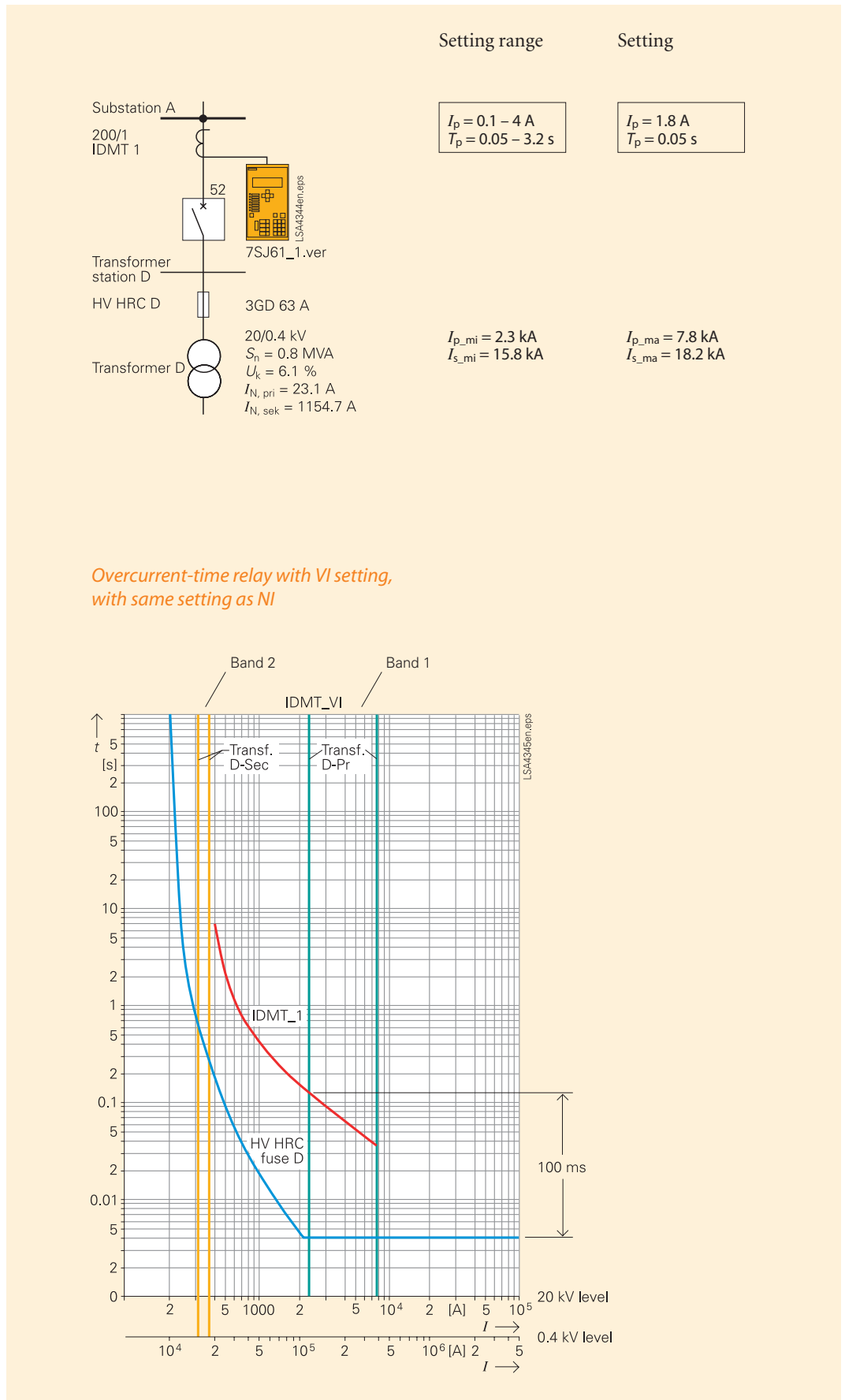
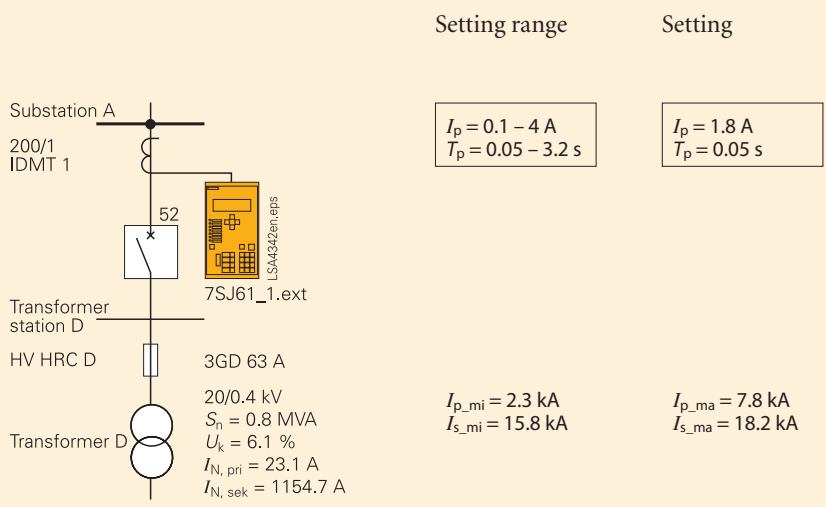

Fig. 10
Time-grading diagram,
very inverse, with
setting like normal
inverse



Overcurrent-time relay with EI setting,
with same setting as NI

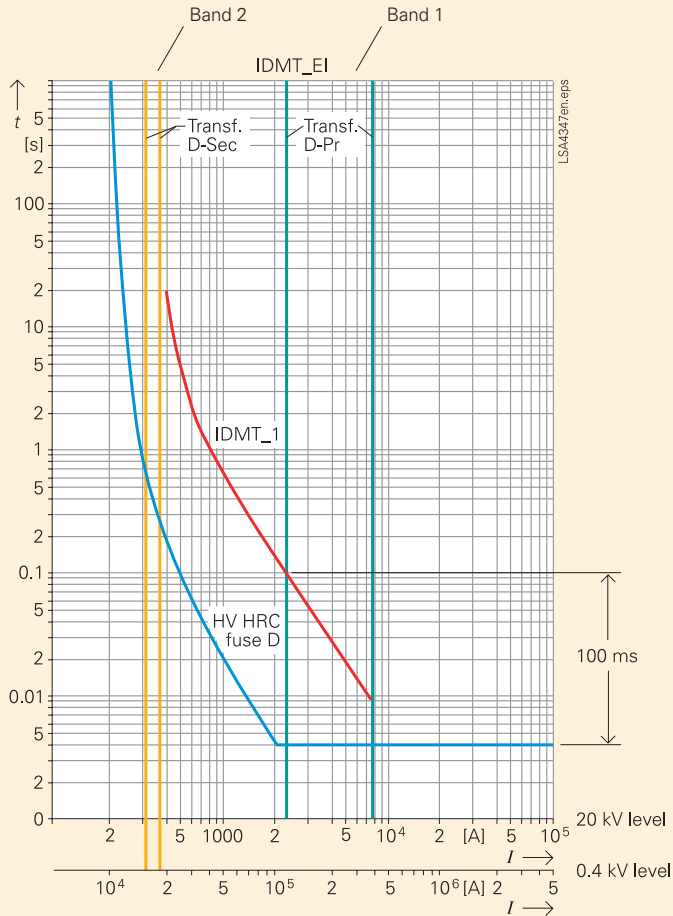

Fig. 11
Time-grading diagram,
extremely inverse, with
setting like normal in-
verse

For the transformer considered (20/0.4 kV, $S_n = 0.8$ MVA, $U_k = 6.1\%$), a 63 A HV HRC fuse is selected according to the above-mentioned selection tables.

In order to maintain selectivity, the target trip time is approx. 100 ms for the overcurrent-time relay setting in the various characteristics with maximum short-circuit current on the 20 kV side. Under the same short-circuit conditions the HV HRC fuse trips in approx. 1 ms.

By setting the I_p appropriately, the maximum fault on the LV side does not lead to pickup of the overcurrent-time relay. As can be seen in Fig. 10 the characteristic begins on the right, next to the maximum short-circuit current (brown, vertical lines). The following setting values should be used to achieve a safe grading time of 100 ms between all types of o/c inverse-time characteristics (NI, VI, EI) and the characteristic of the fuse.

Fig.	$I_p \times I_N$	T_p (s)	Characteristics
7	1.8	0.05	Normal inverse (NI)
8	1.8	0.15	Very inverse (VI)
9	1.8	0.45	Extremely inverse (EI)

Table 2

When comparing the three figures it is clear that the area between the HV HRC and inverse-time characteristics is smallest for the setting NI. Therefore the NI setting must be preferred in this example.

In order to explain the difference in the characteristics more clearly, two diagrams are shown with the characteristics VI and EI with the same setting values as NI.

Very inverse (VI)	Extremely inverse (EI)
$I_p = 1.8$	$I_p = 1.8$
$T_p = 0.05$	$T_p = 0.05$
See Fig. 10	See Fig. 11

Table 3

Conclusion

The steeper the slope of the characteristic the lower the tripping time with maximum fault current. The safe grading time from the HV HRC characteristic becomes smaller. The coordination shown here of the protection devices is only part of the power system and must be adapted to the concept of the overall power system with all protection relays.

Note:

In this example there was no setting of $I >>$, because the inverse-time characteristics themselves trip in the ≤ 0.2 s range in the event of the maximum or minimum 20 kV side fault.

7. Summary

This application example demonstrates the engineering effort necessary to achieve a selective time grading.

Real power systems are more complex and equipped with various protection relays. Whatever the circumstances, it is necessary to know the operating mode of the power system (parallel, generator, meshing, spur lines etc) as well as to calculate the rated and short-circuit currents. It is worth the effort for the protection engineer because the objective is to lose only the faulty part of the power system.

SIGRADE software effectively supports grading calculations. Power system planning and time grading calculation is also offered by Siemens.

8. References

- Günther Seip: Elektrische Installationstechnik
- Siemens: Manual for Totally Integrated Power Catalog HG12: HV HRC Fuses
- SIGRADE Software V3.2
- Manual 7SJ61: Multifunctional Protective Relay with Bay Controller 7SJ61