

Protection of Long Lines with SIPROTEC 7SD5

1. Introduction

The protection of long transmission lines was previously the domain of distance protection. Modern available information transmission technology – with the ability to reliably exchange comparison signals over substantial distances – makes differential protection interesting for use on long transmission lines. High sensitivity and strict selectivity are further aspects that speak in favor of differential protection. The SIPROTEC 7SD5 relay provides, in addition to differential protection, comprehensive backup protection and additional functions for the complete protection of transmission lines.

2. Protection concept

This application example describes largely differential protection of two-end lines. In addition to this use, modern SIPROTEC differential protection relays can meet the following requirements:

- Protection of multi-branch configurations
- Transformer in the protected zone
- Matching to various transmission media such as fiber optics or digital communication networks

For protection of a two-end line, we recommend to activate the following functions:

- ANSI 87 L Differential protection
- ANSI 67 N Directional overcurrent protection
- ANSI 79 Auto-reclosure
- ANSI 50 BF Breaker failure protection
- ANSI 59/27 Undervoltage and overvoltage protection
- ANSI 25 Synchro-check and voltage check



Fig. 1 SIPROTEC 7SD5 line differential protection relay

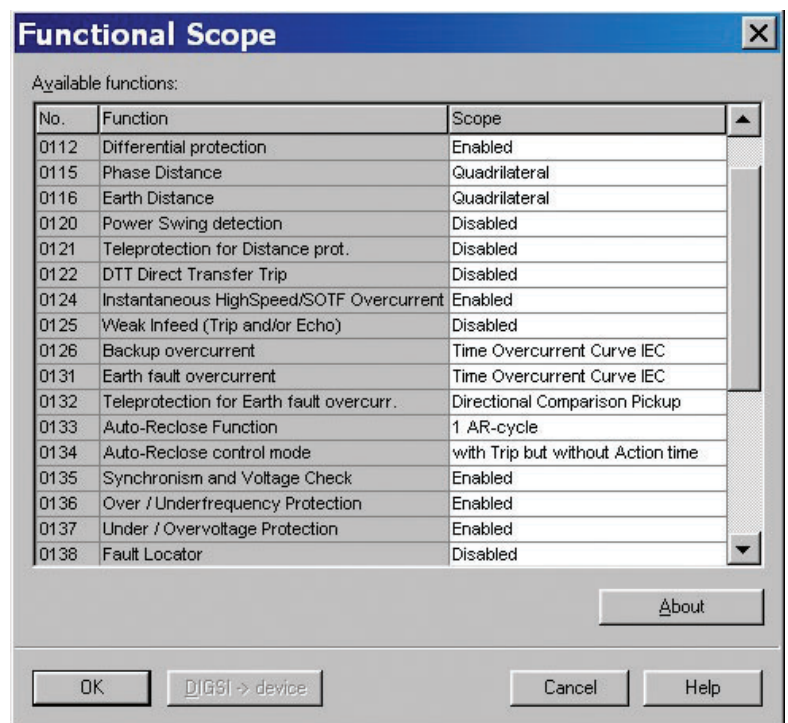

Fig. 2 Settings for functional scope

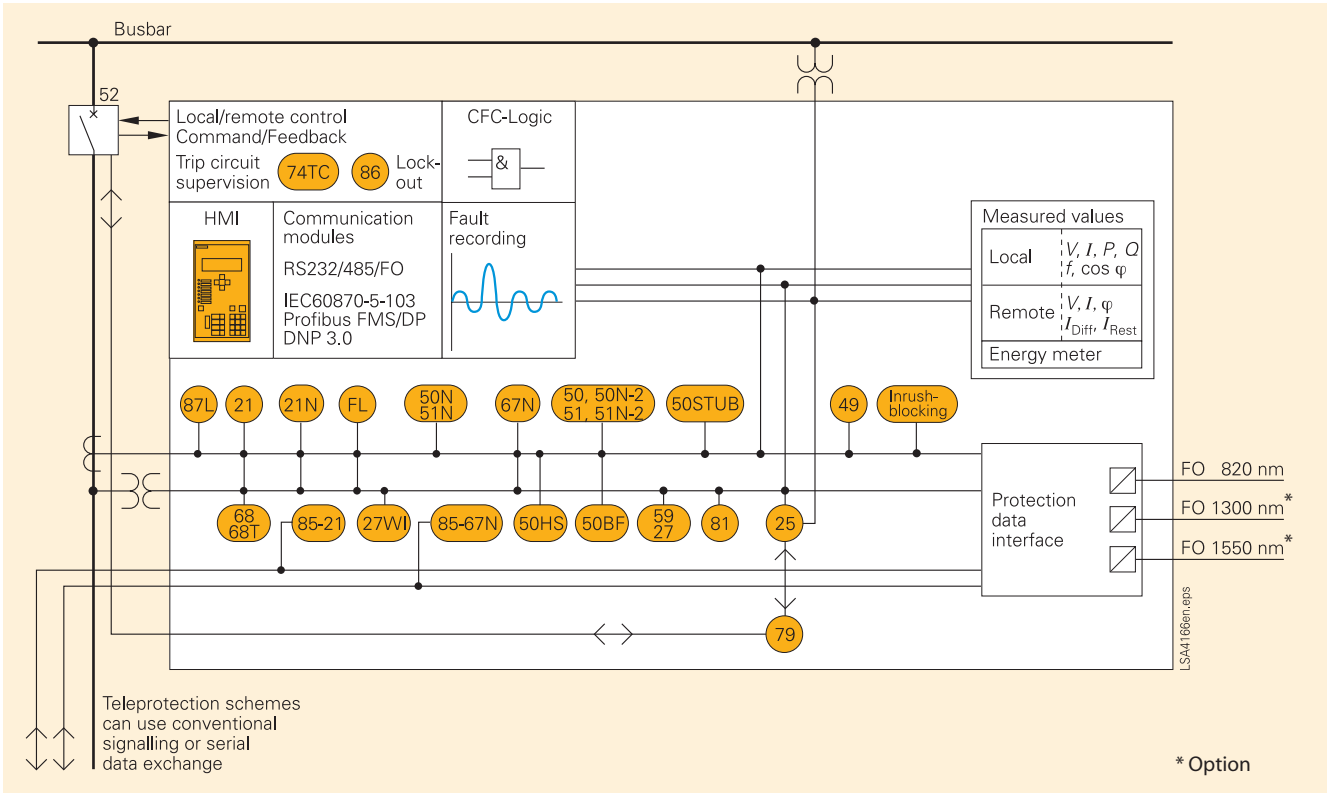

Fig. 3 Function scope of the SIPROTEC 7SD5

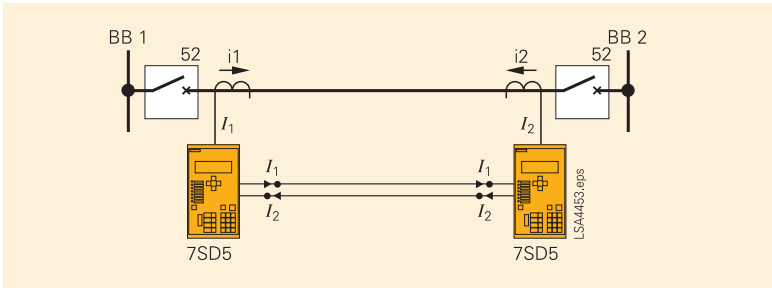

Fig. 4 Differential protection for a line with two ends (single-phase system)

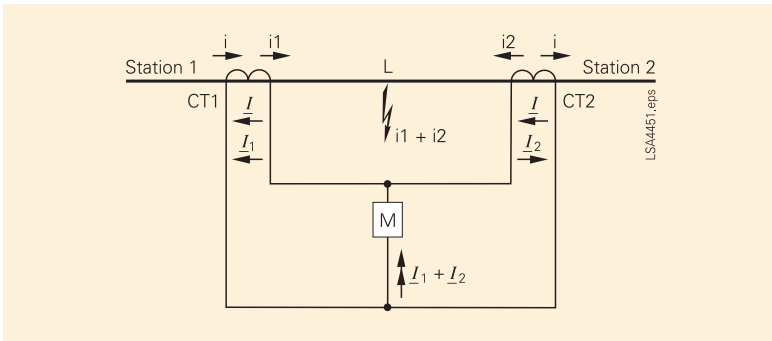

Fig. 5 Basic principle of the differential protection for a line with two ends

2.1 Differential protection

Differential protection is based on current comparison. It makes use of the fact, that e.g. a line section L (Fig. 5) carries always the same current I at its two ends in fault-free operation. This current flows into one side of the considered zone and leaves it again on the other side. A difference in current is a clear indication of a fault within this line section. If the actual current transformation ratios are the same, the secondary windings of the current transformers CT1 and CT2 at the line ends can be connected to form a closed electric circuit with a secondary current I ; a measuring element M which is connected to the electrical balance point remains at zero current in fault-free operation.

When a fault occurs in the zone limited by the transformers, a current $i_1 + i_2$ which is proportional to the fault currents $I_1 + I_2$ flowing in from both sides is fed to the measuring element. As a result, the simple circuit shown in Fig. 5 ensures a reliable tripping of the protection if the fault current flowing into the protected zone during a fault is high enough for the measuring element M to pick up.

2.2 Charging current compensation

Charging current compensation is an additional function for differential protection. It allows an improvement in the sensitivity, achieved by the charging current (caused by the capacitances in the overhead line or cable and flowing through the distributed capacitance in steady state) being compensated. As a result of the capacitances of the phase conductors (to earth and mutually), charging currents flow – even in fault-free conditions – and cause a difference in the currents at the ends of the protected zone. Particularly on cables and long lines the capacitive charging currents can reach considerable levels. If the feeder-side transformer voltages are connected to the relays, the influence of the capacitive charging currents can be largely arithmetically compensated. It is possible here to activate charging current compensation, which determines the actual charging current. Where there are two line ends, each relay attends to half the charging current compensation; where there are M relays, each covers an M^{th} fraction. Fig. 6 shows a single-phase system, for the sake of simplicity.

In fault-free operation, steady-state charging currents can be considered as practically constant, as they are determined only by the voltage and the line capacitances. Without charging current compensation, they must therefore be taken into account when setting the sensitivity of the differential protection. With charging current compensation, there is no need to consider them at this point. With charging current compensation, the steady-state magnetization currents across shunt reactances (quadrature-axis reactances) are also taken into account.

2.3 Directional overcurrent protection (ANSI 67 N)

The zero-sequence current is used as measured quantity. According to its definition equation it is obtained from the sum of three phase currents, i.e. $3I_0 = I_{L1} + I_{L2} + I_{L3}$.

The direction determination is carried out with the measured current $I_E (= -3I_0)$, which is compared to a reference voltage U_P .

The voltage required for direction determination U_P may be derived of the starpoint current I_Y of an earthed transformer (source transformer), provided that the transformer is available. Moreover, both the zero-sequence voltage $3U_0$ and the starpoint current I_Y of a transformer can be used for measurement. The reference magnitude U_P then is the sum of the zero-sequence voltage $3U_0$ and a value which is proportional to reference current I_Y . This value is about 20 V for rated current (Fig. 7).

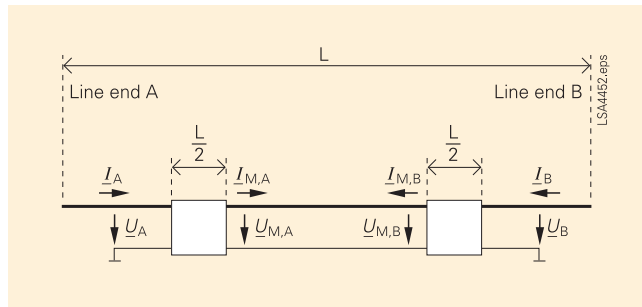

Fig. 6 Charging current compensation for a line with two ends (single-phase system)

The directional polarization using the transformer starpoint current is independent of voltage transformers and therefore also functions reliably during a fault in the voltage transformer secondary circuit. It is, however, a requirement that not all, but at least a substantial amount of the earth-fault current flows via the transformer, the starpoint current of which is measured.

For the determination of direction, a minimum current $3I_0$ and a minimum displacement voltage, which can be set as $3U_0$, are required. If the displacement voltage is too small, the direction can only be determined if it is polarized with the transformer starpoint current and this exceeds a minimum value corresponding to the setting I_Y . The direction determination with $3U_0$ is inhibited if a “trip of the voltage transformer mcb” is reported via binary input.

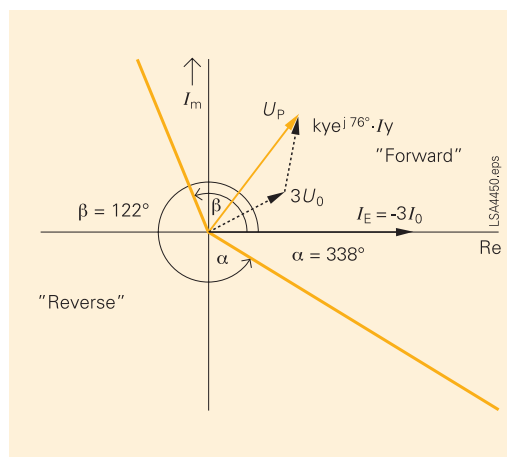

Fig. 7 Directional characteristic of the earth-fault protection

2.4 Auto-reclosure function (ANSI 79)

The 85 % of the arc faults on overhead lines are extinguished automatically after being tripped by the protection. This means that the line can be reclosed. Auto-reclosure is only permitted on overhead lines because the option of automatic extinguishing of an arc fault only exists there. It should not be used in any other case. If the protected object consists of a combination of overhead lines and other equipment (e.g. overhead line directly connected to a transformer or a combination of overhead line/cable), it must be ensured that reclosure can only be performed in the event of a fault on the overhead line. If the circuit-breaker poles can be operated individually, a single-phase auto-reclosure is usually initiated for single-phase faults and a three-pole auto-reclosure for multiple phase faults in the system with earthed system starpoint. If the earth fault still exists after auto-reclosure (arc has not disappeared, there is a metallic fault), then the protection functions will re-trip the circuit-breaker. In some systems several reclosing attempts are performed. In a model with single-pole tripping, the 7SD5 allows phase-selective, single-pole tripping. A single and three-pole, single and multiple-shot auto-reclosure function is integrated, depending on the version.

The 7SD5 can also operate in conjunction with an external auto-reclosure device. In this case, the signal exchange between 7SD5 and the external reclosure device must be effected via binary inputs and outputs. It is also possible to initiate the integrated auto-reclose function by an external protection device (e.g. a backup protection). The use of two 7SD5 with auto-reclosure function or the use of one 7SD5 with an auto-reclosure function and a second protection with its own auto-reclosure function is also possible.

Reclosure is performed by an auto-reclosure function (AR). An example of the normal time sequence of a double reclosure is shown in Fig. 8. The integrated auto-reclosure cycle allows up to 8 reclose attempts. The first four reclose cycles may operate with different parameters (action and dead times, single/three-pole). The parameters of the fourth cycle also apply for the fifth cycle and onwards.

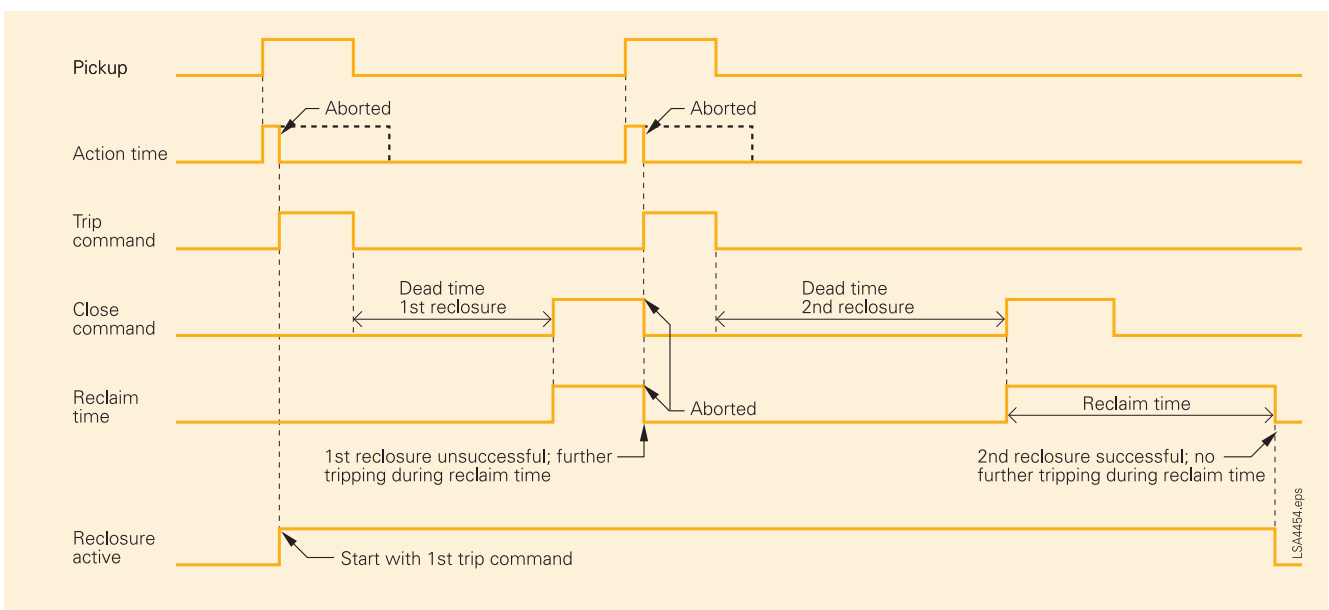

Fig. 8 Timing diagram of a double-shot reclosure with action time (2nd reclosure successful)

2.5 Breaker failure protection (ANSI 50BF)

The breaker failure protection provides rapid backup fault clearance, in the event that the circuit-breaker fails to respond to a trip command from a protection function of the local circuit-breaker. Whenever, e.g., a protection relay of a feeder issues a trip command to the circuit-breaker, this is repeated to the breaker failure protection. A timer in the breaker failure protection is started. The timer runs as long as a trip command is present and current continues to flow through the breaker poles.

2.6 Undervoltage and overvoltage protection (ANSI 27/59)

Voltage protection has the function of protecting electrical equipment against undervoltage and overvoltage. Both operational states are unfavorable as overvoltage may cause, for example, insulation problems or undervoltage may cause stability problems.

The overvoltage protection in the 7SD5 detects the phase voltages U_{L1-E} , U_{L2-E} and U_{L3-E} , the phase-to-phase voltages U_{L1-L2} , U_{L2-L3} and U_{L3-L1} , as well as the displacement voltage $3U_0$. Instead of the displacement voltage any other voltage that is connected to the fourth voltage input U_4 of the relay can be detected. Furthermore, the relay calculates the positive-sequence voltage and the negative-sequence voltage, so that the symmetrical components are also monitored. Here, compounding is also possible which calculates the voltage at the remote line end.

The undervoltage protection can also use the phase voltages U_{L1-E} , U_{L2-E} and U_{L3-E} , the phase-to-phase voltages U_{L1-L2} , U_{L2-L3} and U_{L3-L1} , as well as the positive-sequence system voltage.

2.7 Synchro-check and voltage check (ANSI 25)

The synchro-check and voltage check functions ensure, when switching a line onto a busbar, that the stability of the system is not endangered. The voltage of the feeder to be energized is compared to that of the busbar to check conformance in terms of magnitude, phase angle and frequency within certain tolerances. Optionally, deenergization of the feeder can be checked before it is connected to an energized busbar (or vice versa).

The synchro-check can either be conducted only for auto-reclosure, only for manual closure (this includes also closing via control command) or for both cases. Different close permission (release) criteria can also be programmed for automatic and manual closure. Synchronism check is also possible without external matching transformers if a power transformer is located between the measuring points. Closing is released for synchronous or asynchronous system conditions.

In the latter case, the relay determines the time for issuing the close command such that the voltages are identical the instant the circuit-breaker poles make contact.

The synchronism and voltage check function uses the feeder voltage – designated with U_{Line} – and the busbar voltage – designated with U_{Bus} – for comparison purposes. The latter may be any phase-to-earth or phase-to-phase voltage.

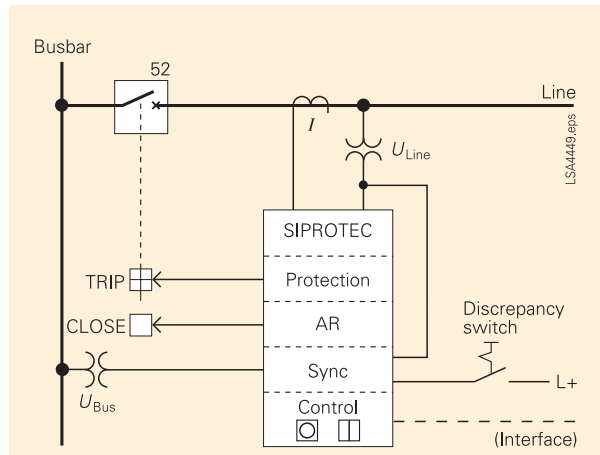

Fig. 9 Synchronism check on closing

If a power transformer is located between the feeder voltage transformers and the busbar voltage transformers (Fig. 10), its vector group can be compensated for by the 7SD5 relay, so that no external matching transformers are necessary.

The synchronism check function in the 7SD5 usually operates in conjunction with the integrated automatic reclose, manual close, and the control functions of the relay. It is also possible to employ an external automatic reclosing system. In such a case, signal exchange between the devices is accomplished via binary inputs and outputs.

When closing via the integrated control function, the configured interlocking conditions may have to be verified before checking the conditions for synchronism. After the synchronism check grants the release, the interlocking conditions are not checked a second time.

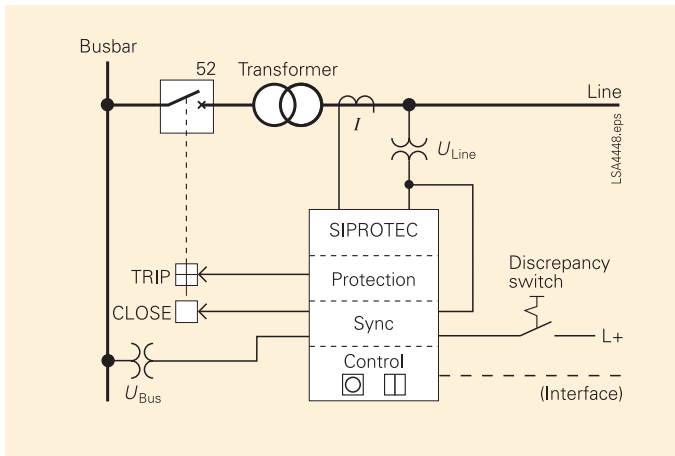

Fig. 10 Synchronism check across a transformer

Communications media

The exchange of signals between the line differential protection relays becomes particularly complicated due to the geographic coverage of the relays over medium and long distances. At the minimum, two substations find themselves using relays of the same system that exchange data over a relay-to-relay (R2R) communication channel.

It is very important to note, however, that the tripping times of the different protection relays depend on the transmission quality and are prolonged in case of a reduced transmission quality and/or an increased transmission time. Fig. 11 shows some examples for communication connections. In case of a direct connection the distance depends on the type of the optical fiber. Table 1 lists the options available. The modules in the relays are replaceable. If an external communication converter is used, the relay must be equipped with an FO5 module in order to achieve correct operation. The relay and the external communication converter are linked via optical fibers. The converter itself allows connections to communication networks, two-wire copper lines or ISDN (Fig. 12).

To span larger distances with fiber-optic cables, it is presently recommended to use external repeaters. Optical modules for distances of up to 100 km are being developed and will be available in 2005.

A further option is the connection via communication network (no limitation of distance).

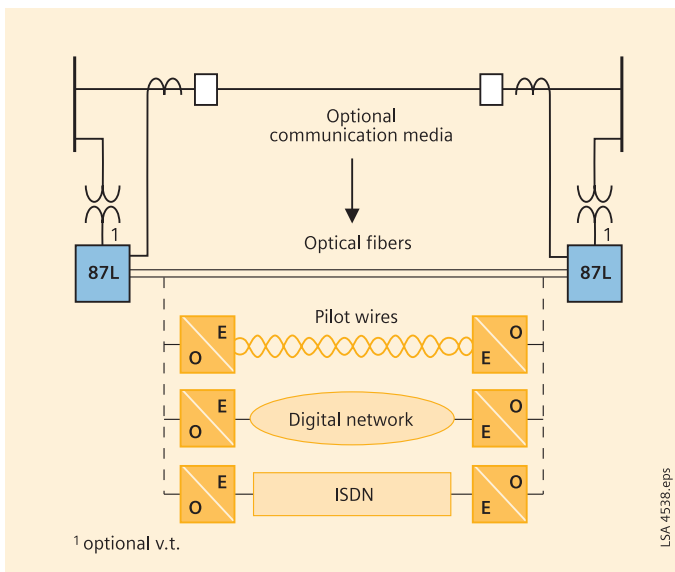

Fig. 11 Optional communication media

The communication is enabled via pilot wire or direct optical fiber connections or via communication networks. Which kind of FO media is used, depends on the distance and on the communication media available (Table 1). For shorter distances a direct connection via optical fibers having a transmission rate of 512 kBit/s is possible. A transmission via modem and communication networks can also be realized.

Module in the relay	Connector type	FO type	Optical wavelength	Perm. path attenuation	Distance, typical
FO5	ST	Multi-mode 62.5/125 μm	820 nm	8 dB	1.5 km (0.95 miles)
FO6	ST	Multi-mode 62.5/125 μm	820 nm	16 dB	3.5 km (2.2 miles)
FO7	ST	Mono-mode 9/125 μm	1300 nm	7 dB	10 km (6.25 miles)
FO8	FC	Mono-mode 9/125 μm	1300 nm	18 dB	35 km (22 miles)
FO17 ¹⁾	LC	Mono-mode 9/125 μm	1300 nm	13 dB	24 km (14.9 miles)
FO18 ¹⁾	LC	Mono-mode 9/125 μm	1300 nm	29 dB	60 km (37.5 miles)
FO19 ¹⁾	LC	Mono-mode 9/125 μm	1550 nm	29 dB	100 km (62.5 miles)

Table 1 Communication via direct FO connection

1) For direct connection over short distances, a suitable optical attenuator should be used to avoid malfunctions and damage to the relay.

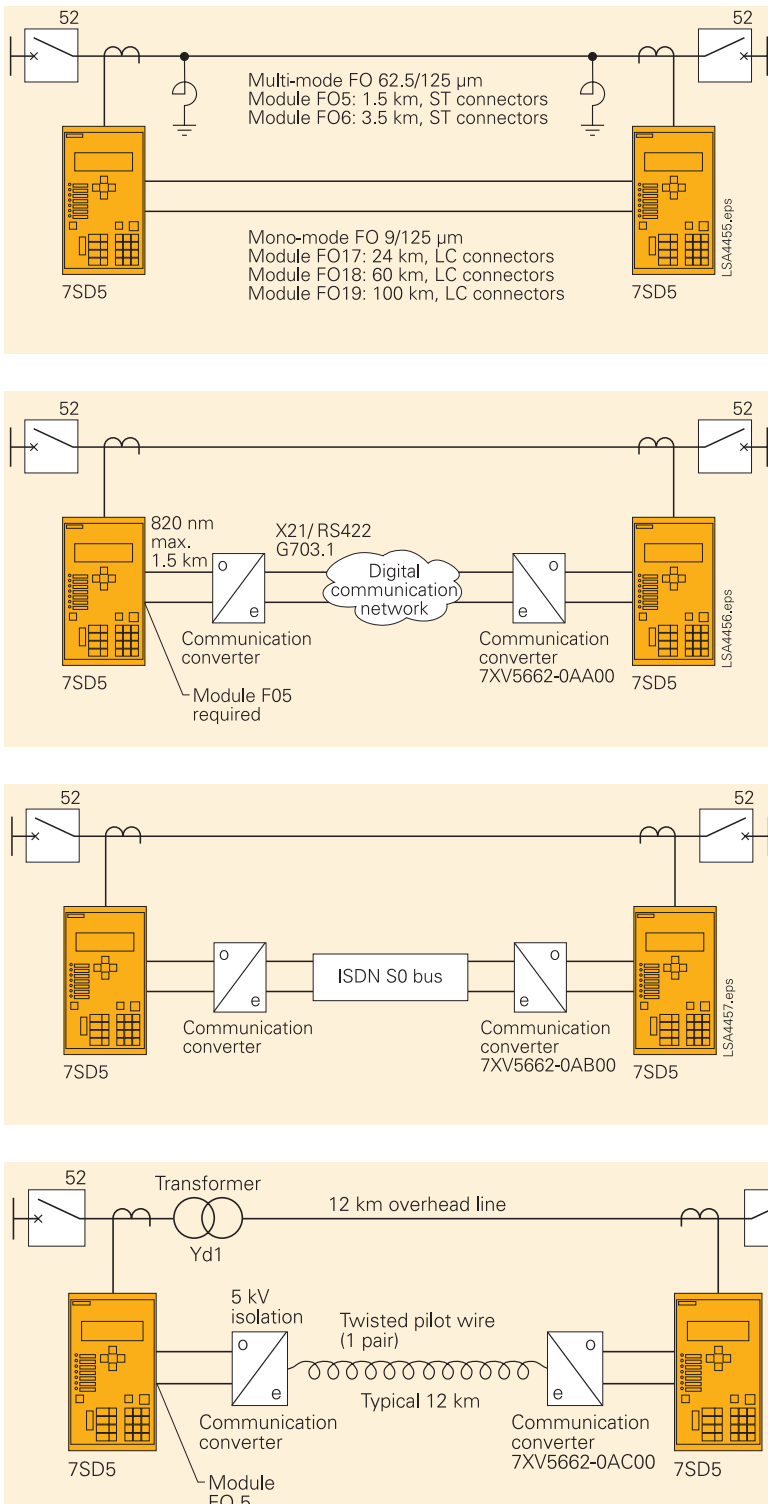

Fig.12 Examples for communication links

■ 3. Summary

Optimal protection of transmission lines with SIPROTEC 7SD5 relays means high selectivity in fault clearing; any available parallel duplicate line remains reliably in operation. Very short release times ensure the stability of the transmission system in the event of a fault, and consequently contribute significantly to maximizing the level of supply security.

The SIPROTEC 7SD5 relay provides comprehensive main and backup protection of transmission lines in a single relay. Thanks to its flexible communication capabilities, the SIPROTEC 7SD5 can be easily matched to the existing communication infrastructure.