

System Solutions for Protecting Medium and Large Power Station Units

■ 1. Introduction

Electrical protection is essential for reliable operation and high availability in power stations. Electrical protection equipment cannot prevent faults from occurring in the power station unit itself, but can limit the damage and thereby shorten the station's downtime.

Protection equipment will not be discussed in detail here. Detailed reports on protection functions and measurement procedures can be found in "Protection of a Medium-Sized Generator up to 5 MW" and "Protection of Medium-Sized and Large Generators with SIPROTEC 7UM6."

The subject of this publication is the design of protection systems with regard to reliability, availability and operational safety. Various equipment technologies (and how these affect the design and operation of a protection system) are compared.

■ 2. Safety and availability of the protection system

Protection equipment serves to detect faults or impermissible operating conditions in power supply systems and to shut them down when such conditions occur. When the station is operating trouble-free, conventional protection equipment does not indicate whether it is functioning correctly or not. The operator must therefore check to make sure that the protection relays are working, using recurrent function tests. This confirmation of correct operation only applies for the duration of the function test. For the time between such periodic function tests, no dependable statement about the condition of the protection relays can be made. Maintenance and testing is discussed in more detail in Chapter 4 of this application example.



Fig. 1 SIPROTEC Generator protection for power stations

Possible failures in electromechanical protection relay can go unnoticed and the relay then almost always fails to function properly. Availability of the protection system is no longer ensured. For this reason the protection equipment for large-scale plants – including of course large power station units – is duplicated. The statistical probability that both protection relays will fail at the same time is so slight that the availability of a redundant protection system can be considered as sufficient (see Fig. 2).

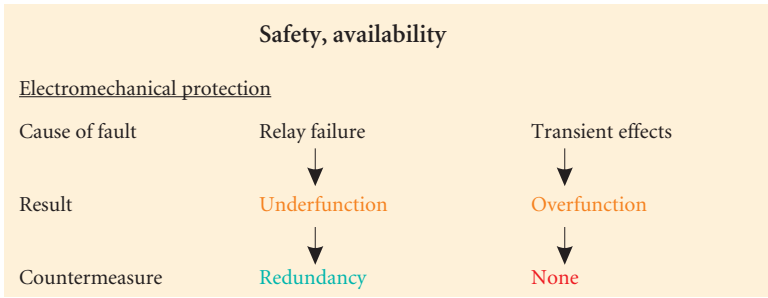

Fig. 2 Safety design for electromechanical protection

In the use of analog electronic protection relays an additional aspect comes into play. A fault on an electromechanical protection relay almost always causes relay failure. A relay fault in an analog static protection relay can cause either underfunction or overfunction, with approximately the same probability. Underfunction can, as with electromechanical protection systems, be mastered by redundant design. The danger of overfunction can be prevented in a limited sense by dual-channel design of the measuring circuits (see Fig. 3).

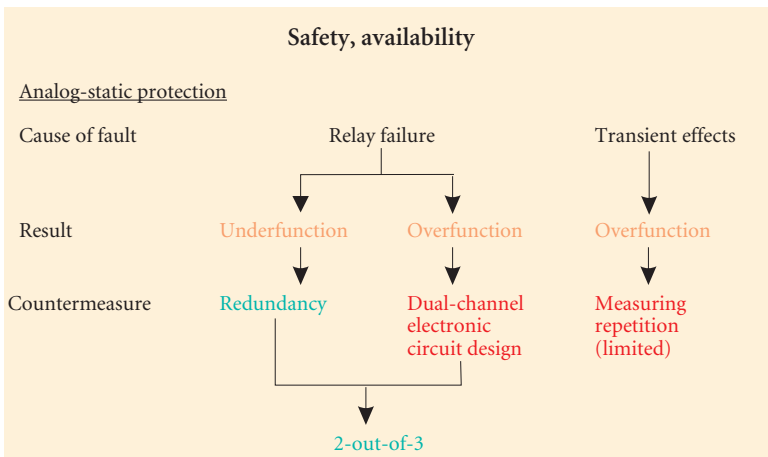

Fig. 3 Safety design for analog-static protection

If a high level of safety and availability is to be attained with analog technology, the 2-out-of-3 principle can be applied. Three identical or equivalent protection systems must be linked with each other externally so that two tripping signals from different systems are always connected in series. This way a very high level of safety from overfunction and underfunction can be achieved.

In a study in the 1970s the safety and reliability of different analog protection system configurations were statistically researched (see Table 1).

System design	Underfunction	Overfunction
1-out-of-1	5 years	5 years
1-out-of-2	600 years	2,5 years
2-out-of-2	2,5 years	21,750 years
2-out-of-3	200 years	7,250 years

Table 1 Overview system design

The MTBF (Mean Time Between Failures) was calculated for different system configurations. The 2-out-of-3 system in analog design offers the highest reliability against overfunction and underfunction. However, a 2-out-of-3 system is technically very complex and cost-intensive and for this reason only used in a few nuclear power plants.

A notable characteristic of numerical protection relays are continuous self-monitoring of hardware and software. Reliability against overfunction and underfunction is inherently provided (see Fig. 4). Any relay failure causes blocking of individual protection functions or of the entire relay. This provides an effective measure against overfunction of the protection relays and thereby of the protection system as a whole. Relay failure is signaled at the same time. This feature means that defective protection relays can be immediately replaced and the statistical availability of the protection system is enhanced.

In power stations that either have a relatively low-output or are of comparatively minor significance for secure power supplies, the requirement for a redundant protection system can consequently be re-assessed. If brief shutdown of the plant is acceptable, the investment costs can be reduced by dispensing with redundancy. "Brief" here means a period of one or two days until the replacement equipment is installed and put into operation.

In most power stations, however, shutdown due to defective protection relays is not acceptable nor is continued operation without complete protection. Consequently, a redundant protection system must be considered in medium and large power station units. From a technical point of view, complete redundancy of the protection functions enables continuous operation of the unit for a short time until defective protection relays are replaced.

For the sake of completeness, the influence of transient phenomena on the behavior of protection relays (Figs. 2, 3 and 4) must be mentioned. Electromechanical protection relays offered, apart from their time-lag characteristics, practically no effective compensation for transient influences. With analog technology, disturbing transient measured variables can be eliminated to a certain extent by multiple measurements. Only numerical technology enables reliable control of transient disturbances through consistent digital filtering and repeat measurements.

Producing complete redundancy does not require 100% duplication of all protection relays. Redundancy can also be achieved by two different measurement procedures for one and the same fault. For example a redundant protection concept can be realized against short-circuits by combining current differential protection and impedance protection in mutually independent relays. For some protection functions, differing measurement principles are even desirable. Duplicate differential protection provides two fast and selective protection against short-circuits in the machine. Impedance protection as the second stage of short-circuit protection includes at the same time backup protection against power system faults (see Figs. 5 and 6).

A few special features must be noted in the redundant design of protection functions whose principle is based on supplying an external voltage (100% stator earth-fault protection with 20 Hz injection and rotor earth-fault protection). The auxiliary devices cannot be operated in duplicate on the generator. It is, however, possible and appropriate to operate the protection functions themselves in redundancy. Here, the measuring inputs of both protection relays are fed in parallel from the same 20 Hz or 1 Hz frequency generator. If a very high level of statistical availability is aimed for, the auxiliary devices can be installed in duplicate with one changeover switch in the protection cabinet. If any auxiliary devices fails, the parallel relay is activated by the changeover switch.

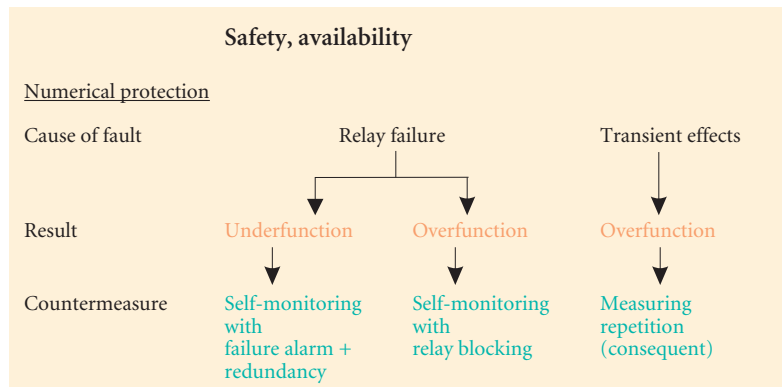

Fig. 4 Safety design for numerical protection

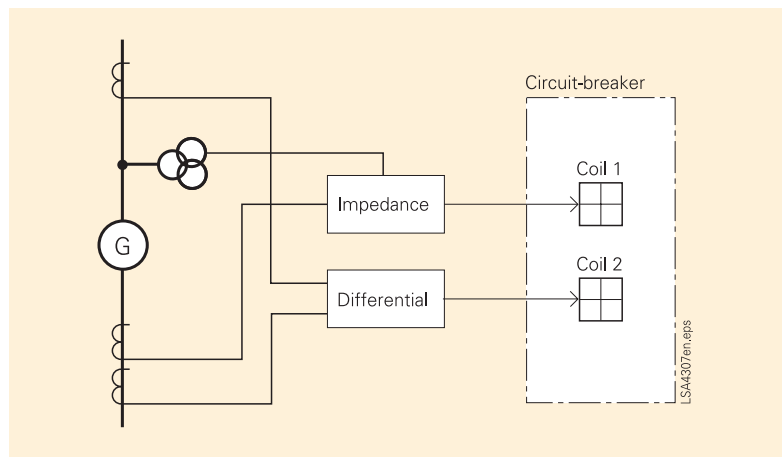

Fig. 5 Diverse redundancy: Backup protection against system faults

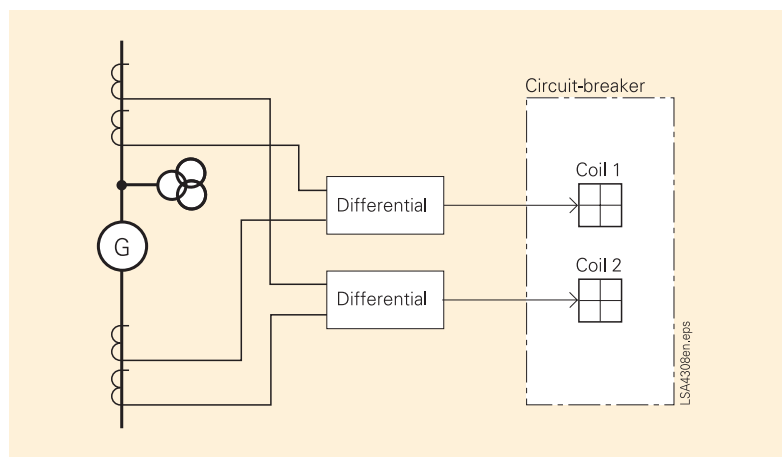

Fig. 6 Mirrored redundancy: No backup protection against system faults

■ 3. Indication processing and communication

Numerical protection relays offer the operator considerably more scope for status and fault indications than do conventional relays. In the interests of more reliable operation and control of the power station, it is the planning engineer's responsibility, from the abundance of available information, to provide (to operating personnel) precisely those indications and measured values that are needed for each task. Rather than succumbing to the temptation to make all available information accessible at each workstation, the planning engineer is responsible for working out an intelligent indication signalling concept.

This means that each member of staff receives the information needed to make quick and reliable decisions about technical operation and control of the power station. Fig. 7 provides a concept for such an information network. Group indications from the protection system are provided in the

also be requested via the bus connection as necessary. An information network with connected PC is available for detailed fault analysis after tripping on faults has occurred. Via this means of communication, the protection expert can read out all the available information from the protection relays. Using the message lists and the transient fault records the expert can draw up an exact profile of the fault that led to the power station unit being shut down. Alternatively, this detailed information can be read out on the front of the protection relays.

■ 4. Maintenance and testing

Continuous self-monitoring of numerical protection relays creates new opportunities for operation and testing. While it was essential to monitor the state of conventional protection relays by means of periodic function tests, numerical protection relays do most of this work themselves.

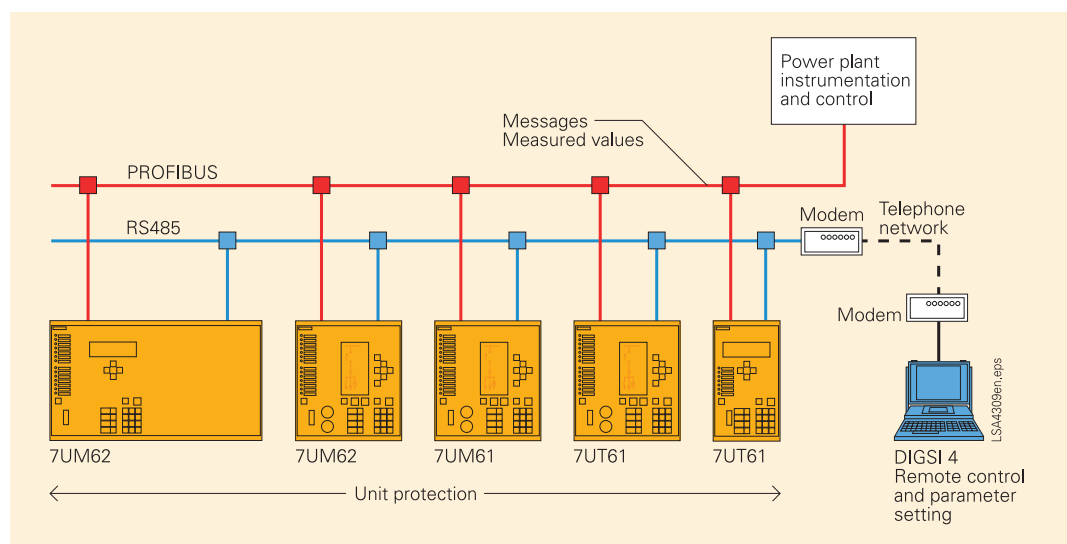

Fig. 7 Integration of protection relays into power station control and protection system

power station control room. These indications enable a quick overview of the operating state of the power station unit in terms of electrical faults or impermissible operating states. The recommended spontaneous indications for the control room are:

- Tripping on faults
- Protection faulty
- Negative-sequence (unbalanced load) alarm
- Stator earth-fault alarm
- Rotor earth-fault alarm
- Underexcitation alarm

In addition to these spontaneous indications, measured values from the protection relays can

The self-monitoring installed in each numerical protection relay continuously checks that the hardware and software are working correctly. This produces a series of consequences for maintenance and testing of a numerical protection system.

Protection relays can be regularly checked by feeding in fault currents and voltage over a longer period of time. Such overall testing should be carried out in the context of regular power station maintenance. Since this check does not take place during operation of the power station, special test switches or plugs are not necessary. Current and voltage is fed in via the cabinet terminals. In view of the multi-functional protection relay concept for generators it is practically impossible to test individual protection functions without intervening in the relay parameterization. This is also not necessary because all protection functions of a relay are handled on the same hardware. The conventional approach involving protection characteristics with measurement of tolerances is not provided in numerical protection. Thanks to digital measured-value processing, the ageing or temperature drift of analog components is nowadays practically unknown. The function test is thus limited to a sensitivity check of the protection relay as a whole.

During power station operation the self-monitoring performs continuous testing of the numerical protection relays. As well as monitoring the program flow using Watchdog, the correct condition of the hardware components is continually checked. This takes place for example using write/read cycles for the memory and with the processing of reference parameters for the analog/digital converter. The protection relay also monitors external connections, where possible. One example of many is monitoring of the measuring voltage balance (Figs. 8 and 9).

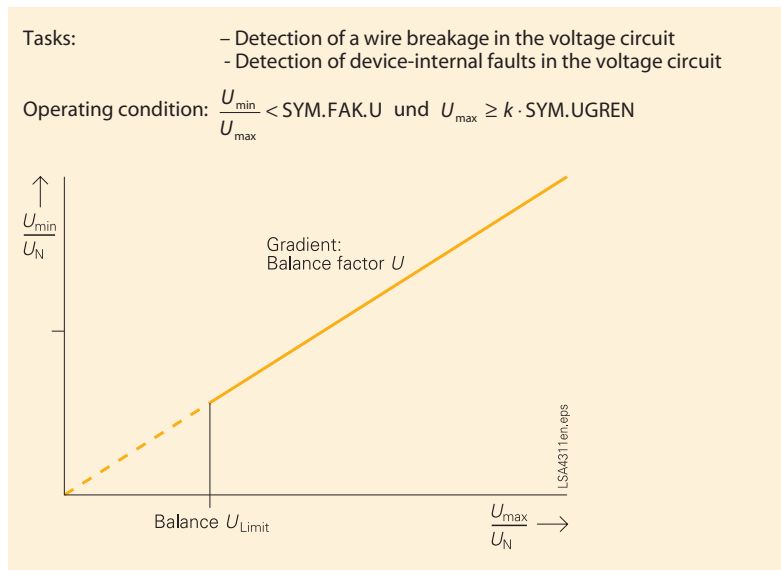

Fig. 9 Voltage balance monitoring

As a reaction to an identified fault, a defective protection relay produces either just an indication or blocks itself partly or wholly to prevent overfunction. Taking into account the recognized fault, the protection relay reacts in a graded way according to the seriousness of the fault (Fig. 10).

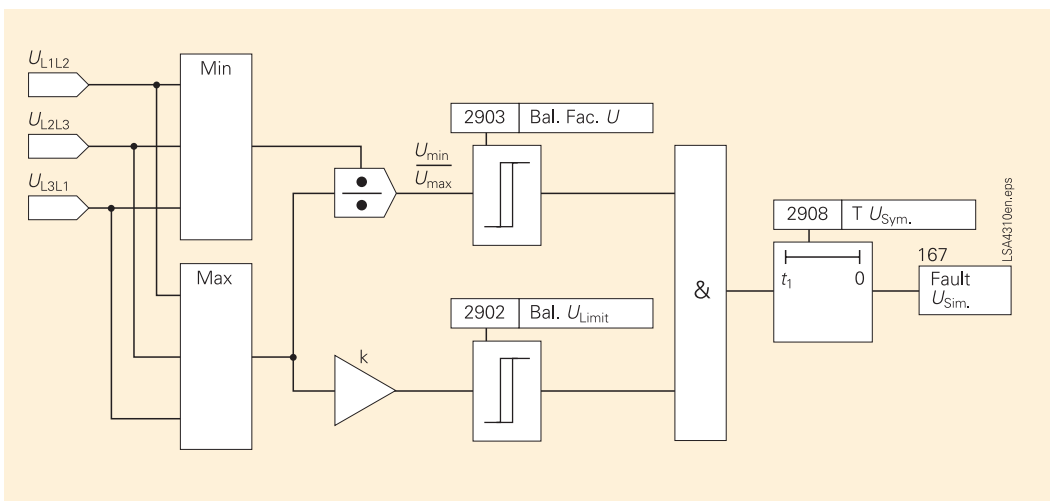

Fig. 8 Voltage balance monitoring

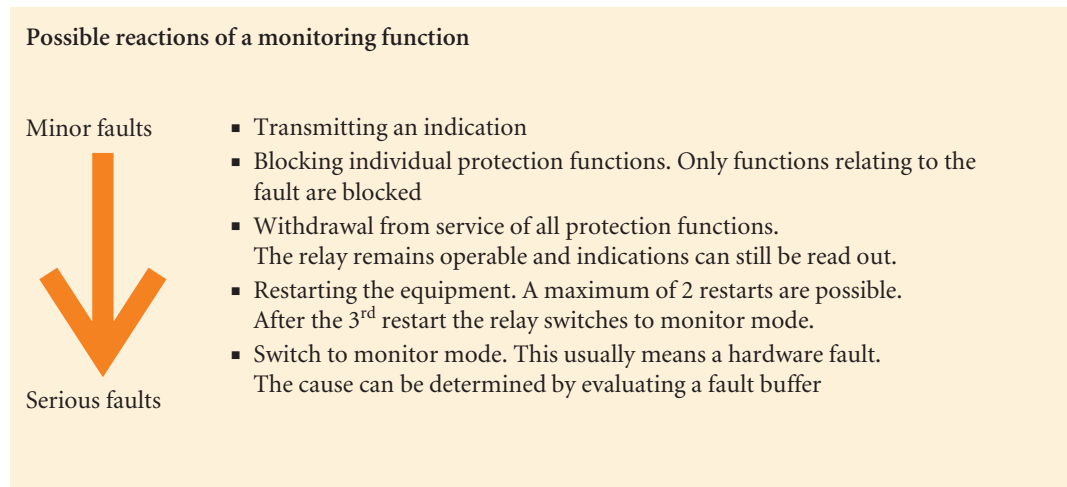

Fig. 10 Design of monitoring functions

During normal power station operation, numerical protection relays make it possible to check the complete measured-value acquisition circuit by reading out status measured-values. Measured values can be indicated on the equipment display without adversely affecting the protection functions. A comparison of these measured values with other measuring devices or protection relays represents an inspection and test sequence which would be unthinkable in conventional technology without additional equipment. This test step includes the following power station and device components:

- Current and voltage transformer
- Transformer supply cables
- Cubicle wiring for the measuring circuits
- Input measuring transmitter for the protection relays
- Analog/digital converter
- Measured-value memory

This inspection and test sequence is of minimal duration and can be carried out at any time, without intervening in the protection processing of the relay.

■ 5. Summary

The development of numerical technology for protection relays brought about considerable benefits in terms of enhanced performance, reliability and availability of the protection system. These benefits upgrade the availability of the power supply system. Quantity and quality of information retrieved from the numerical protection relays have reached such a high level that operation and maintenance of the power station can be performed much safer and with less efforts. The increase in functionality in the numerical protection relays requires a well-designed protection and information system, making the best of the many different opportunities.