

Application of Low-Impedance 7SS601 Busbar Differential Protection

■ 1. Introduction

Utilities have to supply power to their customers with highest reliability and minimum down time. System disturbances, especially short-circuits, cannot always be avoided. They are caused by human error, accidents, nature's influence such as storm, lightning, etc...

However, damage to primary equipment, such as transformers, switchgear, overhead lines, etc. must be limited in order to reduce the repair time and, thus, the downtime.

Although busbar faults are rare, they are considered most dangerous for people (staff) and the switchgear. Hence, fast tripping in case of busbar faults is essential!

This can be achieved primarily by differential protection.

Especially in medium and high-voltage switchgear, busbar differential protection is often regarded as an expensive accessory. However, responsible engineers are aware of the risk of extensive outages, if busbar faults are not cleared fast and selectively.

Siemens offers with its 7SS601 low-impedance busbar differential protection a low-cost solution, particularly suitable for single busbar with or without bus sectionalizer or simple double busbar configurations.

The 7SS601 combines important advantages of numerical protection with a cost-effective and an easy-to-use protection system:

- Self-supervision, fault logging and event recording, setting with DIGSI required for only a few parameters.
- Highest flexibility with regard to busbar configuration, number of feeders, different CT-ratios, low CT requirements.
- Measured-value acquisition by summation or matching current transformers (phase-selective)
- Fast and selective tripping for all busbar faults.
- Suitable for all voltage levels, up to 500 kV

The following article describes the basics of low-impedance busbar protection; some of its typical applications on a single busbar with bus sectionalizer with disconnect switch or bus sectionalizer with circuit-breaker).

The example is tailored for a solidly earthed network.



Fig. 1 SIPROTEC 7SS601 centralized numerical busbar protection relay

■ 2. Principle of low-impedance protection

Fig. 2 illustrates the basic principle of the low-impedance protection.

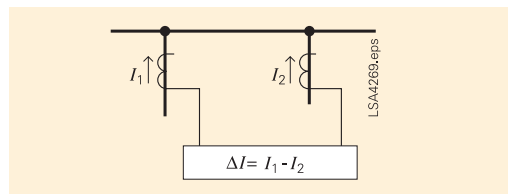

Fig. 2 Principle of differential protection

Differential protection is based on the Law of Kirchhoff: in a healthy system, the sum of currents in a node must be zero. This is the ideal case. But CT errors and measuring errors need to be considered. For that reason, the protection needs to be stabilized.

The differential criteria and the restraint criteria are defined as follows:

$$\text{Differential current: } I_{\text{Diff}} = |I_1 + I_2 + \dots + I_n|$$

$$\text{Restraint current: } I_{\text{Restraint}} = |I_1| + |I_2| + \dots + |I_n|$$

Fig. 3 shows, how I_{Diff} and $I_{\text{Restraint}}$ are being derived.

It can be seen, that for load or through-flowing currents the differential criteria is almost zero, whereas the restraint quantity rises instantly. In case of an internal fault both, the differential and the restraint quantity rise at the same time. Hence, even within a few milliseconds, the protection relay can decide whether there is an internal or external fault.

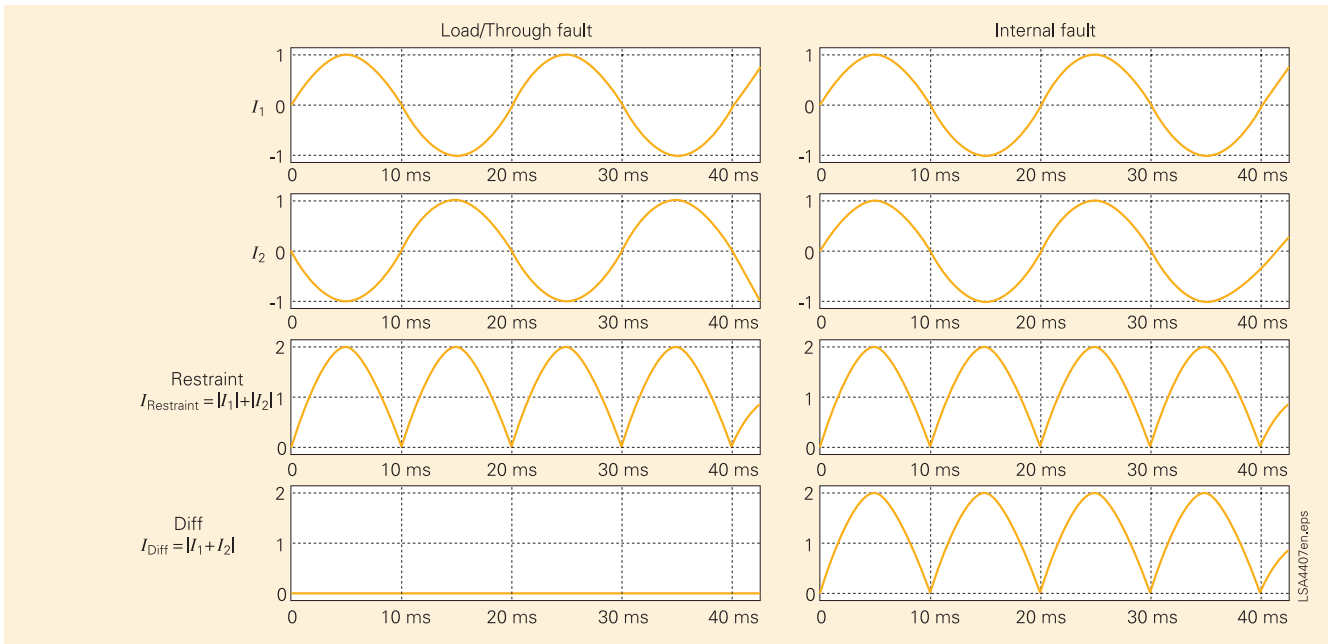

Fig. 3
Derivation of I_{Diff} and $I_{Restraint}$

For more than 50 years Siemens has been using this kind of stabilized differential protection. It was introduced for the first time in the electro-mechanical protection 7SS84, later in the analog static protection 7SS10 and is now being employed in the numerical protections 7SS52 and 7SS601.

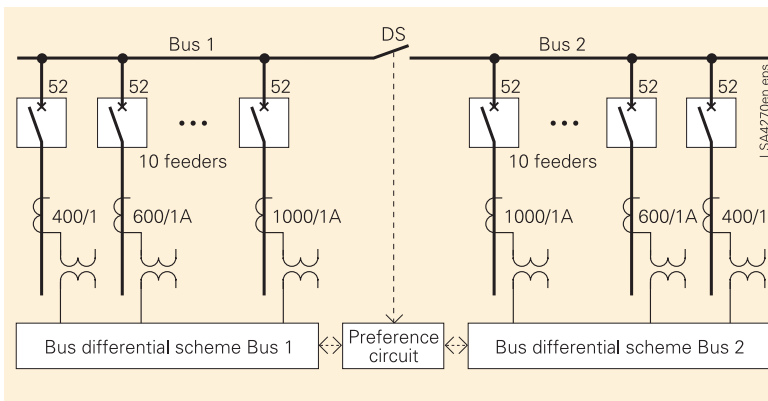

Fig. 4 Single busbar with disconnect in bus sectionalizer

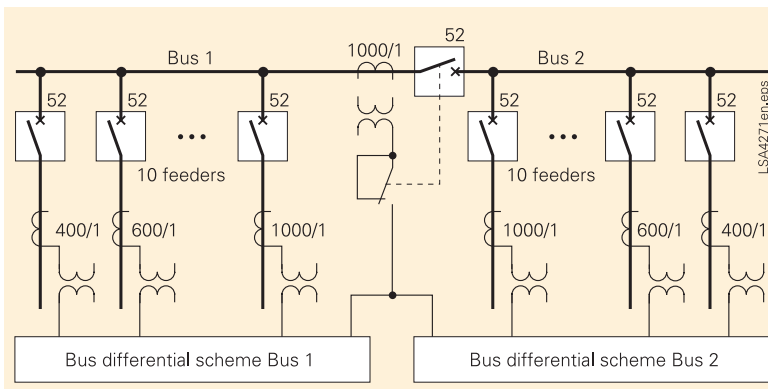

Fig. 5 Single busbar with circuit-breaker in bus sectionalizer

■ 3. Protected objects

Fig. 4 and 5 show examples with 10 feeders on each bus section. However, the number of feeders per bus section is not limited.

3.1 Single busbar with disconnect (DS) in bus sectionalizer. In this case, no CTs are used in the bus sectionalizer. See Fig. 4

3.1.1 If the DS is open, both measuring systems (bus differential schemes) work independently. In case of a busbar fault, only the circuit-breakers (52) connected to the faulty bus will be tripped.

3.1.2 If the DS is closed the busbar must be considered as “one unit”. The preference circuit (preferential treatment module) will switch the currents of all feeders to one measuring system only. In case of a busbar fault, all circuit-breakers will be tripped.

3.2 Single busbar with circuit-breaker and a CT in the bus sectionalizer. See Fig. 5.

3.2.1 If the circuit-breaker is open, both systems work independently. In case of a busbar fault, only the CBs connected to the faulty bus will be tripped.

Since the circuit-breaker is open, the CT is not required for measurement and thus shorted. In case of a fault between the circuit-breaker and the CT in the bus sectionalizer, system 1 will detect the fault as “internal” and trip all CBs connected to bus 1.

3.2.2 If the circuit-breaker in the bus sectionalizer is closed both systems work independently. In case of a busbar fault, all circuit-breakers connected to the faulty busbar will be tripped. The circuit-breaker in the bus sectionalizer will be tripped by both systems. In case of a fault between the circuit-breaker in the bus sectionalizer and the CT, system 2 will detect this fault as “internal” and trip all circuit-breakers of bus 2 including the circuit-breaker in the bus sectionalizer.

System 1 remains stable for the time being. Once the circuit-breaker in the bus sectionalizer has tripped, the CTs are shorted. Now system 1 will detect this fault also as “internal” and finally clears the fault by tripping the circuit-breakers of bus 1.

■ 4. Summation current transformers and adaptation of different CT ratios

The advantage of the low-impedance scheme is that other protection relays may be connected in series with the summation or matching current transformers (Fig. 6). This reduces the overall costs of the switchgear.

As mentioned earlier, the low-impedance scheme can process different CT ratios. Thus, upgrading of existing switchgear with low-impedance busbar protection is easily possible without changing or adding CT cores!

The standard connection of a summation current transformer is shown in Fig. 7. The summation current transformer is used to do a “magnetic” summation of the currents. The resulting currents depend on the ratio of the windings. The following calculation shows some examples of how the currents of the summation current transformers are being calculated.

It can be shown that the optimum ratio of the primary windings are 2:1:3. This ensures increased sensitivity for earth faults.

Example: $W_{P1} = 60$ windings
 $W_{P2} = 30$ windings
 $W_{P3} = 90$ windings
 $W_S = 500$ windings (fixed)

General equation:

$$i_p \cdot W_p = i_s \cdot W_s \Rightarrow i_s = i_p \frac{W_p}{W_s}$$

For the above example: assume $i = I_N = 1$ A

$$\underline{i}_{L1} = 1 \text{ A} \frac{W_{P1} + W_{P3}}{W_S} = 1 \text{ A} \frac{150}{500} = 0.3 \text{ A} \Rightarrow 0.3 \cdot e^{j0}$$

$$\Rightarrow \underline{i}_{L1} = 0.3 + j0$$

$$\underline{i}_{L2} = 1 \text{ A} \frac{W_{P2}}{W_S} = 1 \text{ A} \frac{30}{500} = 0.06 \text{ A} \Rightarrow 0.06 \cdot e^{j120}$$

$$\Rightarrow \underline{i}_{L2} = -0.09 + j0.156$$

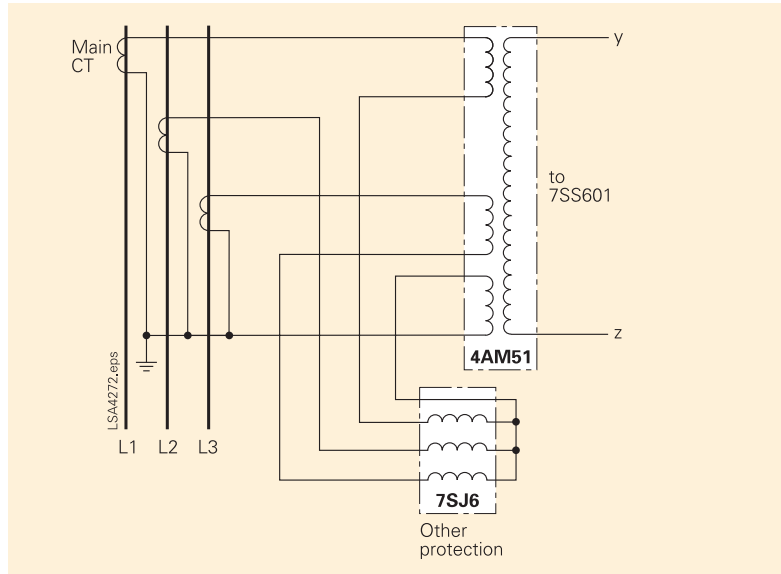

Fig. 6 Serial connection of summation CTs with other relays

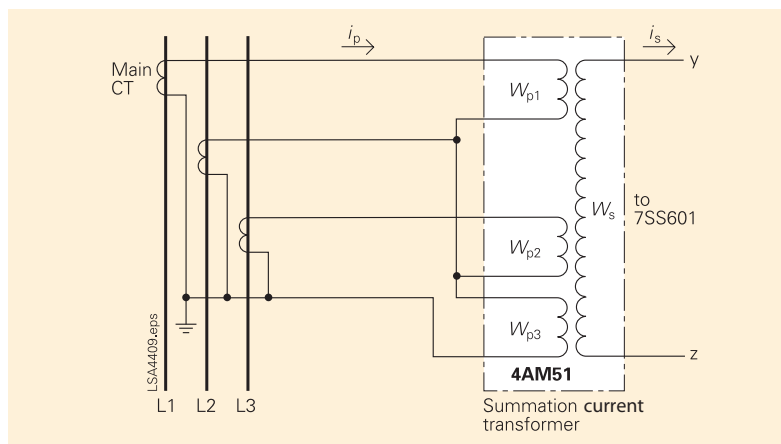

Fig. 7 Standard connection of summation current transformer

W_p = primary winding of summation current transformer
 W_s = secondary winding of summation current transformer

$$\underline{i}_{L3} = 1 \text{ A} \frac{W_{P2} + W_{P3}}{W_S} = 1 \text{ A} \frac{120}{500} = 0.24 \text{ A}$$

$$\Rightarrow 0.24 \cdot e^{j240} \Rightarrow \underline{i}_{L3} = -0.12 - j0.21$$

Result: summation $\underline{i}_{L1} + \underline{i}_{L2} + \underline{i}_{L3} = \underline{i}_s$

$$\underline{i}_s = 0.09 - j0.054 \Rightarrow \underline{i}_s = 0.105 \cdot e^{-j30^\circ}$$

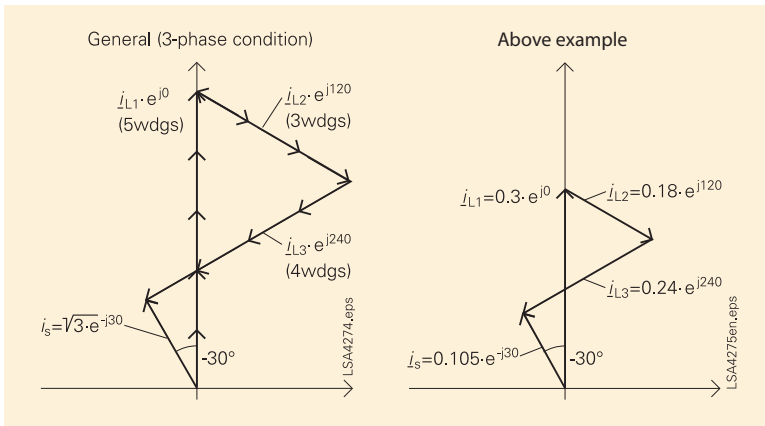

Fig. 8 Phasor diagram of measurements

As can be seen the secondary current is ≈ 100 mA, which corresponds to the rated current of the 7SS601 protection relay. The graphical addition leads to the same result. See Fig. 8.

In order to adapt different CT-ratios, the 4AM5120 summation current transformer has 7 primary windings, which can be combined by means of connecting the windings in series. The 4AM 5120-3DA00-0AN2 summation current transformer is suitable for 1A rated current:

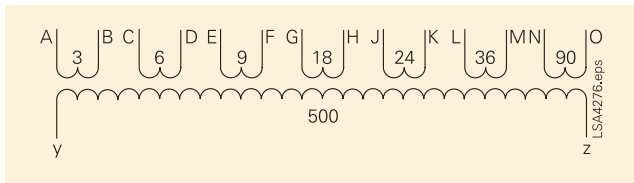

Fig. 9 Tapping of summation current transformers

As mentioned before, the ratio of the primary windings should be 2:1:3 in standard applications. Table 1 shows the most commonly used ratios.

Note

Always be aware of the orientation of the windings !

The examples of Figures 4 and 5 respectively show CT-ratios of 400/1A, 600/1A and 1000/1A.

The differential protection can only compare currents, if the basis for comparison is equal, i.e. the CT-ratios must be matched.

A simple procedure has to be followed:

- The difference in CT-ratios may not exceed 1:10 (i.e. 400 / 600 / 1000 is possible, 200 / 800 / 2500 is not possible).
- The max. possible number of windings of the summation current transformer shall be used. Thus, accuracy is increased.
- The highest CT-ratio is always the reference.

Windings	Reference	Phase	Connections	Links
6-3-9	1	L1 L3 N	C, D A, B E, F	
12-6-18	2	L1 L3 N	A, F C, D G, H	B-E
18-9-27	3	L1 L3 N	G, H E, F A, K	B-J
24-12-36	4	L1 L3 N	J, K A, F L, M	B-E
30-15-45	5	L1 L3 N	C, K B, H E, M	D-J A-G magnetic subtraction F-L
36-18-54	6	L1 L3 N	A, K G, H M, O	B-E, F-J L-N magnetic subtraction
42-21-63	7	L1 L3 N	C, M B, K F, O	D-L A-J magnetic subtraction E-H, G-N magnetic subtraction
48-24-72	8	L1 L3 N	A, M J, K H, O	B-E; F-L G-N magnetic subtraction
54-27-81	9	L1 L3 N	G, M A, K F, O	H-L B-J E-N magnetic subtraction
60-30-90	10	L1 L3 N	J, M A, H N, O	K-L B-E, F-G

Table 1 Selected ratios of summation current transformers at $I_N = 1$ A

- Choose the smallest common integer multiple of the CT-ratios, of which the result of division may not exceed "10".

Example

400 / 600 / 1000 smallest multiple:

2 → 200 / 300 / 500: Not possible !

400 / 600 / 1000 smallest multiple with result ≤ 10 : 100 → 4 / 6 / 10. Possible !

The result of this calculation is used to select the ratios of the summation transformer from Table 1 (Reference number).

400 / 1A → 4 → 24-12-36
 600 / 1A → 6 → 36-18-54
 1000 / 1A → 10 → 60-30-90

Fig. 10 shows that with the above selected ratios the secondary currents of the summation current transformers are equal. The differential protection can now compare all currents.

In case of short-circuits, the sensitivity of the differential protection varies due to the winding ratio 2:1:3 and the resulting secondary currents. Refer to Table 2.

Short circuits	Effective windings W	$\frac{W}{\sqrt{3}}$	I_1 for $i_M = 100$ mA
L1 - L2 - L3	$\sqrt{3}$	1.00	$1.00 \cdot I_N$
L1 - L2	2	1.15	$0.87 \cdot I_N$
L2 - L3	1	0.58	$1.73 \cdot I_N$
L3 - L1	1	0.58	$1.73 \cdot I_N$
L1 - E	5	2.89	$0.35 \cdot I_N$
L2 - E	3	1.73	$0.58 \cdot I_N$
L3 - E	4	2.31	$0.43 \cdot I_N$

Table 2 Result of secondary current matching

To ensure reliable tripping, the minimum short-circuit currents must be above the lowest pickup value of the respective fault type.

Example: Setting of the pickup threshold:

$$I_{Diff} > 1.20 I_{NO}^*$$

* I_{NO} is the rated current of the reference ratio (1000/1 A)

	1000 / 1 A
3-phase faults	1.20
L1 - L2	1.04
L2 - L3	2.08
L3 - L1	2.08
L1 - E	0.42
L2 - E	0.69
L3 - E	0.52

Table 3 Sensitivity of 7S560 according to type of fault

Hence, the minimum short-circuit current must exceed:

- 1200 A for 3-phase faults
- 2080 A for phase to phase faults
- 690 A for phase to ground faults

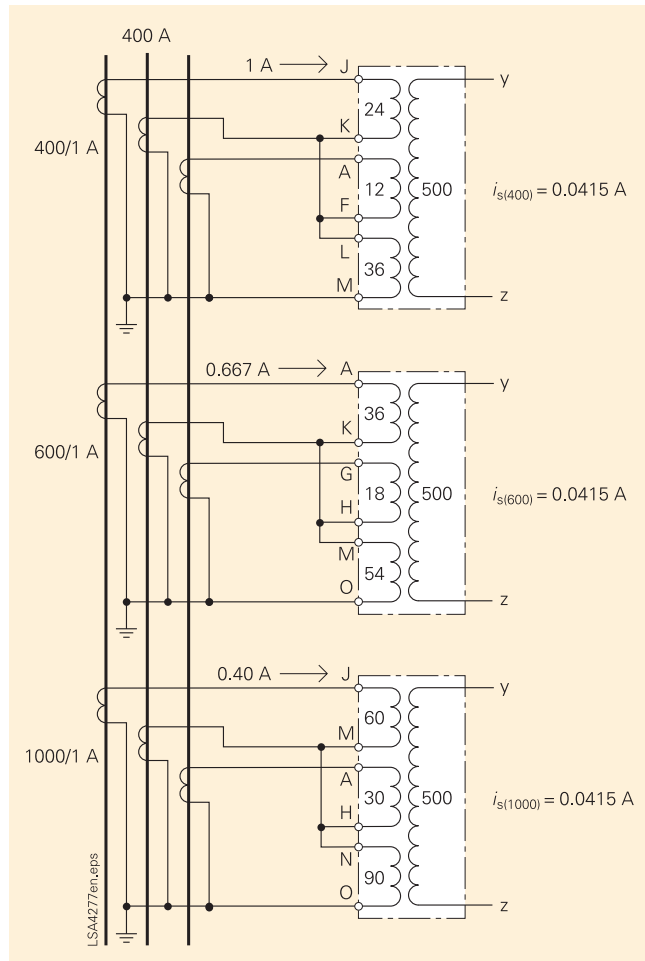

Fig. 10 Adaption of different CT ratios

■ 5. Components of the 7SS601 centralized numerical busbar protection

The basic principles are shown in Fig. 11 and 12: 4AM5120 summation current transformers, restraint/command output 7TM70 modules, 7TR71 isolator replica/preferential treatment module and 7SS601 protection relay are required:

- Summation current transformers: one for each feeder.
- Restraint modules: each module 7TM70 contains 5 input transformers with rectifiers and 5 tripping relays.
- Measuring system(protection relay): one for each bus section.

- 7TR71 preferential treatment/isolator replica module. For allocation of current and preferential treatment via isolator replica.
- 7XP20 housing to accommodate 7TM70 and 7TR71 modules. One housing can accommodate up to 4 modules.

Fig. 11 shows the scheme with a disconnecter in the bus sectionalizer. In this case, 7TR71 is used as preferential treatment module. If the disconnecter is closed the entire bus must be seen as “one unit”. All currents must be measured by one system only. Thus all currents are routed to system 2. The trip circuits of both busses are switched in parallel.

Fig. 11 corresponds to the example shown in Fig. 4.

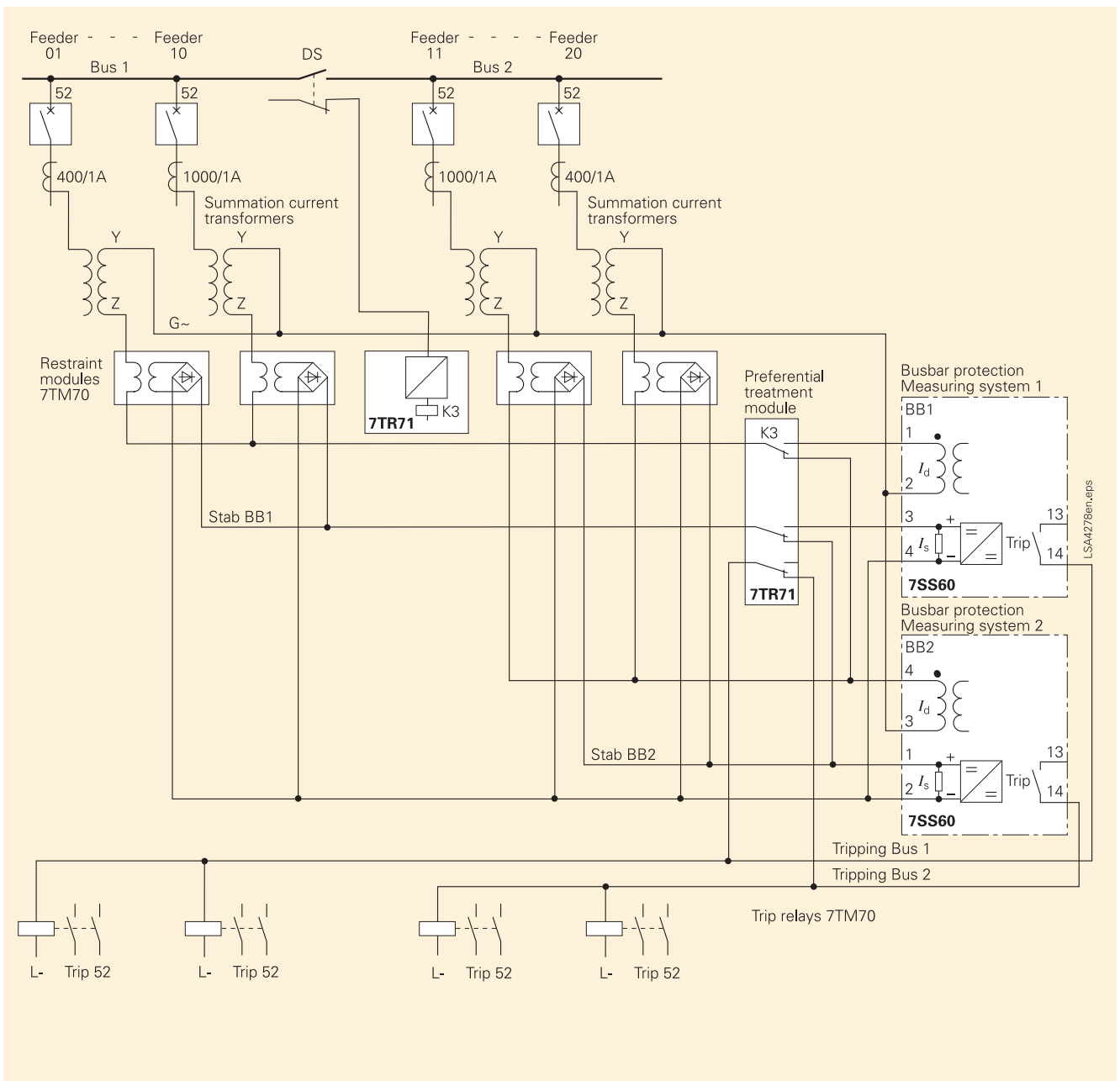

Fig. 11 Block diagram of the 7SS60 with disconnecter in bus sectionalizer

Fig. 12 shows the scheme with a circuit-breaker in the bus sectionalizer. In this case, 7TR71 is used as “circuit-breaker position replica” module. If the circuit-breaker is open, the secondary side of the summation CT is shorted because no current flows in the bus section anyway. If the circuit-breaker is closed, the differential and restraint currents are fed to both measuring systems with opposite direction. In case of a busbar fault, a busbar-selective tripping is possible. The circuit-breaker in the bus sectionalizer will be tripped by both measuring systems.

Fig. 12 corresponds to the example shown in Fig. 5.

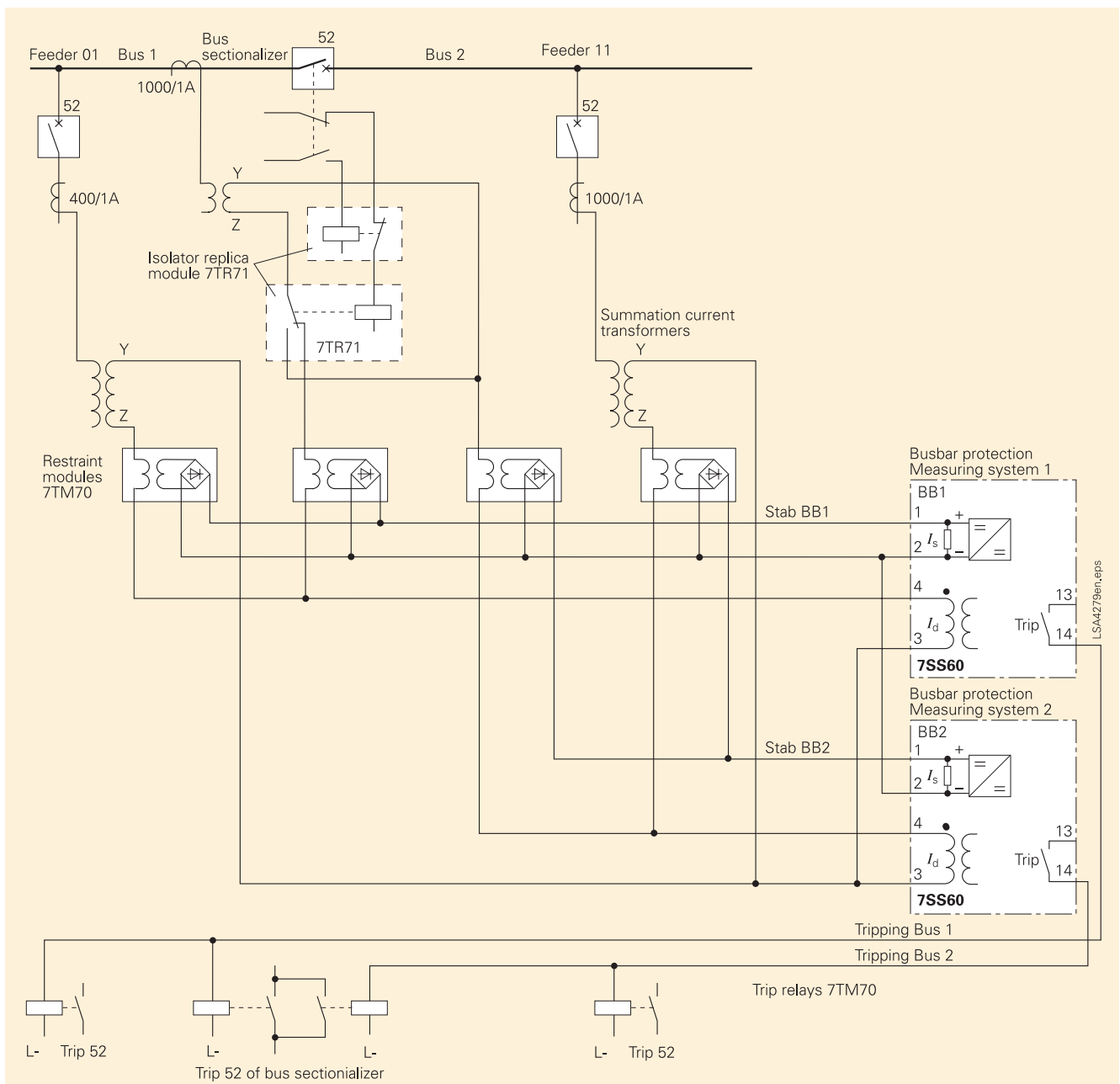

Fig. 12 Block diagram of the 7SS60 with circuit-breaker in bus sectionalizer

Busbar protection for switchgear (20 feeders) as shown in Fig. 11, comprises the following components:

- 20 x 4 AM 5120 summation current transformers (10 feeders on each busbar)
- 4 x 7TM70 restraint modules (4 x 5 inputs = 20 inputs)
- 2 x 7SS601 protection relays
- 1 x 7TR71 preferential treatment module
- 2 x 7XP20 housings

Busbar protection for switchgear (20 feeders + bus sectionalizer with circuit-breaker)

- 21 x 4AM5120 summation current transformers (20 feeders +1 for the sectionalizer)
- 5 x 7TM70 restraint modules (25 inputs)
- 2 x 7SS601 protection relays
- 1 x 7TR71 isolator/CB replica module
- 2 x 7XP20 housings

The above modules can be accommodated in a standard protection cubicle.

Please refer to our documentation (instruction manual, catalog and circuit diagrams) for more details.

■ 6. *Setting and design considerations*

CTs shall be dimensioned such that all CTs transform currents without saturation for at least $\geq 4\text{ms}$.

The number of feeders connected in parallel to one protection relay is unlimited.

Please refer to the instruction manual in case of systems with transformers of which the star point is isolated.

A lock-out function of the trip command may be activated in the 7SS601. No external lock-out relays are required !

Fig. 13 shows the tripping characteristic of the protection relay.

The threshold $I_{d>}$ should be set above max. load current (e.g. $1.2 \cdot I_{\text{Load}}$) to avoid tripping by the load current in case of a fault in the CT circuit. If, however, the minimum short-circuit currents require a lower setting, additional trip criteria may be introduced (e.g. voltage).

On the other hand, to ensure tripping under minimum short-circuit conditions, $I_{d>}$ should be set at about 50 % below minimum short-circuit currents. For instance: $I_{\text{scmin}} = 3000 \text{ A} \rightarrow 50 \% = 1500 \text{ A}$

$I_{d>} = 1.2 I_{\text{NO}}$, if the reference ratio is 1000/1 A.

The threshold $I_{d>\text{CTS}}$ is the pickup value for CT supervision.

If a CT secondary circuit is open or shorted, a differential current will appear. The differential protection will be blocked and an alarm given. This will avoid unnecessary overfunction in case of heavy through-flowing currents.

The k-factor changes the slope of the tripping characteristic as shown in Fig. 13 and thus determines the stability of the protection.

Although a high setting for this factor improves the stability with regard to faults outside the protected zone, it reduces the sensitivity for the detection of busbar faults. The k-factor should therefore be chosen as low as possible and as high as necessary. If the measuring system (protection relay) is to be used for zone-selective protection, which will be the case in most applications, it is advisable to use the presetting of 0.6 of the k-factor.

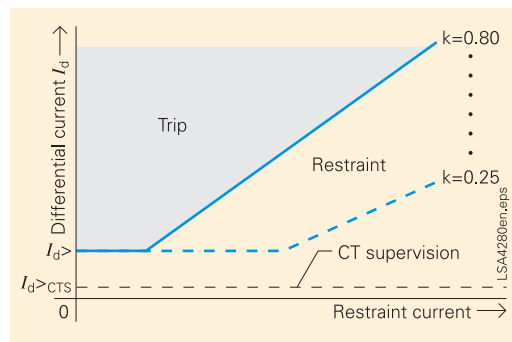

Fig. 13 Tripping characteristic

■ 7. Comparison of high and low-impedance busbar protection

Nowadays high impedance protection is still widely used, because it is considered “cheap and easy”.

But most users only look at the relay price itself, without considering the additional costs for the switchgear and other *disadvantages of a high-impedance schemes*:

- All CTs must have the same ratio
- Class X for all CT cores
- Bus sectionalizers with circuit-breaker must be equipped with two CTs
- Separate CT cores for busbar protection
- Advantages of numerical protection technology (e.g. fault recording, communication, etc.) not available
- Check zone needs separate CT cores
- Isolator replica requires switching of CT secondaries. Additional check zone obligatory.

■ 8. Summary

The low-impedance 7SS601 busbar protection is a cost-effective solution for medium and high-voltage switchgear.

Apart from the application described the 7SS601 can also be applied

- With phase-segregated measurement
- On switchgear with double busbars.

For a quotation, we would need the following information:

- Single-line diagram, showing
 - Busbar configuration
 - Number of feeders, bus sectionalizers with disconnect/circuit-breaker
 - Ratio of CTs
 - Phase-segregated or single phase measurement
 - Complete cubicles or components only

For more information please contact your local Siemens partner.

More details may be obtained from our documentation (instruction manuals, relay catalog SIP2004, CD's). Circuit diagrams for standard applications are available on the Internet at: www.siprotec.com

